

RESIDENTIAL DIRECT VENT GAS WATER HEATERS



GAMA certification applies to all residential gas water heaters with capacities of 20 to 100 gallons with input rating of 75,000 BTU/Hr. or less.

FOR USE ONLY IN MANUFACTURED HOMES

FOR USE ONLY WITH VENTING SYSTEMS SUPPLIED WITH THE WATER HEATER WHETHER A NEW INSTALLATION OR A REPLACEMENT INSTALLATION.



WARNING: If the information in these instructions is not followed exactly, a fire or explosion may result causing property damage, personal injury or death.

- Do not store or use gasoline or other flammable vapors and liquids in the vicinity of this or any other appliance.
- **WHAT TO DO IF YOU SMELL GAS:**
 - Do not try to light any appliance.
 - Do not touch any electrical switch; do not use any phone in your building.
 - Immediately call your gas supplier from a neighbor's phone. Follow the gas supplier's instructions.
 - If you cannot reach your gas supplier, call the fire department.
- Installation and service must be performed by a qualified installer, service agency or the gas supplier.



⚠ WARNING

Read and understand instruction manual and safety messages before installing, operating or servicing this water heater.

Failure to follow instructions and safety messages could result in death or serious injury.

Instruction manual must remain with water heater.

• For Your Safety •

AN ODORANT IS ADDED TO THE GAS USED BY THIS WATER HEATER.

ALL TECHNICAL AND WARRANTY QUESTIONS: SHOULD BE DIRECTED TO THE LOCAL DEALER FROM WHOM THE WATER HEATER WAS PURCHASED. IF YOU ARE UNSUCCESSFUL, PLEASE WRITE TO THE COMPANY LISTED ON THE RATING PLATE ON THE WATER HEATER.





**KEEP THIS MANUAL IN THE POCKET ON HEATER FOR FUTURE REFERENCE
WHENEVER MAINTENANCE ADJUSTMENT OR SERVICE IS REQUIRED.**

SAFE INSTALLATION, USE AND SERVICE

Your safety and the safety of others is extremely important in the installation, use and servicing of this water heater.

Many safety-related messages and instructions have been provided in this manual and on your own water heater to warn you and others of a potential injury hazard. Read and obey all safety messages and instructions throughout this manual. It is very important that the meaning of each safety message is understood by you and others who install, use or service this water heater.

	This is the safety alert symbol. It is used to alert you to potential personal injury hazards. Obey all safety messages that follow this symbol to avoid possible injury or death.
---	--

	DANGER indicates an imminently hazardous situation which, if not avoided, could result in death or injury.
	WARNING indicates a potentially hazardous situation which, if not avoided, could result in death or injury.
	CAUTION indicates a potentially hazardous situation which, if not avoided, may result in minor or moderate injury.
	CAUTION used without the safety alert symbol indicates a potentially hazardous situation which, if not avoided, could result in property damage.

All safety messages will generally tell you about the type of hazard, what can happen if you do not follow the safety message and how to avoid the risk of injury.

IMPORTANT DEFINITIONS

- **Qualified Installer:** A qualified installer must have ability equivalent to a licensed tradesman in the fields of plumbing, air supply, venting and gas supply, including a thorough understanding of the requirements of the National Fuel Gas Code as it relates to the installation of gas fired water heaters. The qualified installer must also be familiar with the design features and have a thorough understanding of this instruction manual.
- **Service Agency:** A service agency also must have ability equivalent to a licensed tradesman in the fields of plumbing, air supply, venting and gas supply, including a thorough understanding of the requirements of the National Fuel Gas Code as it relates to the installation of gas fired water heaters. The service agency must also have a thorough understanding of this instruction manual, and be able to perform repairs strictly in accordance with the service guidelines provided by the manufacturer.
- **Gas Supplier:** The Natural Gas or Propane Utility or service who supplies gas for utilization by the gas burning appliances within this application. The gas supplier typically has responsibility for the inspection and code approval of gas piping up to and including the Natural Gas meter or Propane storage tank of a building. Many gas suppliers also offer service and inspection of appliances within the building.

GENERAL SAFETY



⚠ WARNING

Read and understand instruction manual and safety messages before installing, operating or servicing this water heater.

Failure to follow instructions and safety messages could result in death or serious injury.

Instruction manual must remain with water heater.



⚠ WARNING

Fire Hazard

For continued protection against risk of fire:

- Do not install water heater on carpeted floor.
- Do not operate water heater if flood damaged.

⚠ DANGER

Water temperature over 125°F (52°C) can cause severe burns instantly resulting in severe injury or death.

Children, the elderly, and the physically or mentally disabled are at highest risk for scald injury.

Feel water before bathing or showering.

Temperature limiting valves are available.

Read instruction manual for safe temperature setting.

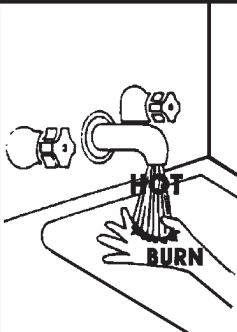

⚠ WARNING

Explosion Hazard

- Overheated water can cause water tank explosion.
- Properly sized temperature and pressure relief valve must be installed in opening provided.

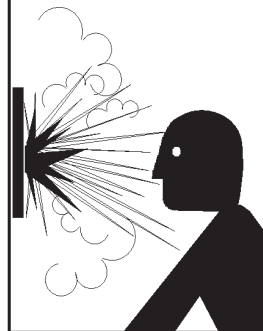

⚠ WARNING

Fire or Explosion Hazard

- Do not expose water heater control to excessive gas pressure.
- Use only gas shown on rating plate.
- Follow conversion instructions listed in manual when converting to opposite gas.
- Maintain required clearances to combustibles.
- Keep ignition sources away from faucets after extended period of non-use.



Read instruction manual before installing, using or servicing water heater.



⚠ WARNING

Breathing Hazard - Carbon Monoxide Gas

- Water heater must be properly vented to a roof jack which terminates outdoors.
- Do not install with any type of vent damper.
- Do not operate water heater if flood damaged.
- High altitude orifice must be installed for operation above 5,000 feet (1,524 m).
- Do not operate if soot buildup.
- Do not obstruct water heater air intake with insulating jacket.
- Do not place chemical vapor emitting products near water heater.
- Gas and carbon monoxide detectors are available.



Breathing carbon monoxide can cause brain damage or death. Always read and understand instruction manual.

⚠ DANGER

Fire or Explosion Hazard

- Do not store or use gasoline or other flammable vapors and liquids in the vicinity of this or any other appliance.



CAUTION

Improper installation and use may result in property damage.

- Do not operate water heater if flood damaged.
- Inspect and replace anode as needed.
- Install in location with drainage.
- Fill tank with water before operation.
- Be alert for thermal expansion.

Refer to instruction manual for installation and service.

TABLE OF CONTENTS

SAFE INSTALLATION, USE AND SERVICE	2	Fuel Conversion Instructions from Propane (L.P.) to Natural Gas	19
GENERAL SAFETY	3	LIGHTING & OPERATING LABEL	20
TABLE OF CONTENTS	4	TEMPERATURE REGULATION	21
INTRODUCTION	4	FOR YOUR INFORMATION	21-22
Preparing for the New Installation	4	Start Up Conditions	21
TYPICAL INSTALLATION	5-6	Condensate	21,22
LOCATING THE NEW WATER HEATER	7	Smoke/Odor	22
Facts to Consider About Location	7-8	Thermal Expansion	22
Insulation Blankets	8-9	Strange Sounds	22
INSTALLING THE NEW WATER HEATER	9-19	Operational Conditions	22
Water Heater Installation	9-10	Smelly Water	22
Securing Water Heater to Floor and Wall	10	“Air” in Hot Water Faucets	22
Roof Jack Installation	11-14	High Temperature Shut Off System	22
Manufactured Home installed Over Basement or Crawlspace-Air Intake Through an Outside wall	12,13	PERIODIC MAINTENANCE	23-25
Cutting Opening Through an Outside Wall and Collar Installation	13	Venting System Inspection	23
Cementing PVC, ABS or CPVC Pipe and Fittings	14	Burner Inspection	23
Water Piping	14	Burner Cleaning	23
T & P Valve and Pipe Insulation	14,15	Housekeeping	23
Water Piping Pressure Test	15	Anode Rod Inspection	24
Temperature Pressure Relief Valve	15,16	Temperature-Pressure Relief Valve Operation	24
Filling the Water Heater	16	Draining	24
Gas Piping	16,17	Drain Valve Washer Replacement	24
Sediment Traps	17	Service	25
Fuel Conversion Instructions from Natural Gas to Propane (L.P.) Gas	17,19	LEAKAGE CHECKPOINTS	25
		TROUBLESHOOTING	26
		REPAIR PARTS	27
		WARRANTY	Insert

INTRODUCTION

Thank You for purchasing this water heater. Properly installed and maintained, it should give you years of trouble free service.

Abbreviations Found In This Instruction Manual:

- CSA - Canadian Standards Association
- ANSI - American National Standards Institute
- NFPA - National Fire Protection Association
- ASME - American Society of Mechanical Engineers
- GAMA - Gas Appliance Manufacturer's Association

This gas-fired water heater is design certified by CSA INTERNATIONAL under American National Standard/CSA Standard for Gas Water Heaters for Manufactured Home Installation, ANSI Z21.10.1 • CSA 4.1 (current edition).

PREPARING FOR THE INSTALLATION

1. Read the “General Safety” section, page 3 of this manual first and then the entire manual carefully. If you don't follow the safety rules, the water heater will not operate properly. It could cause DEATH, SERIOUS BODILY INJURY AND/OR PROPERTY DAMAGE.

This manual contains instructions for the installation, operation, and maintenance of the gas-fired water heater. It also contains warnings throughout the manual that you must read and be aware of. All warnings and all instructions are essential to the proper operation of the water heater and your safety. Since we cannot put everything on the first few pages, **READ THE ENTIRE MANUAL BEFORE ATTEMPTING TO INSTALL OR OPERATE THE WATER HEATER.**

2. Instructions to Manufactured Home Manufacturers:
The installation must conform with the Manufactured Home Construction and Safety Standards Title 24 CFR, Part 3280.

Instruction for replacement installation:

The installation must conform with these instructions and the local code authority having jurisdiction. In the absence of local codes, installations shall comply with the National Fuel Gas Code ANSI Z223.1/NFPA 54. This publication is available from the Canadian Standards Association, 8501 East Pleasant Valley Rd., Cleveland Ohio 44131, or The National Fire Protection Association, 1 Batterymarch Park, Quincy, MA 02269.

3. If after reading this manual you have any questions or do not understand any portion of the instructions, call the local gas utility or the manufacturer whose name appears on the rating plate.
4. Carefully plan the place where you are going to put the water heater. Correct combustion, vent action, and vent pipe installation are very important in preventing death from possible carbon monoxide poisoning and fires, see Figures 1 and 2.

Examine the location to ensure the water heater complies with the “Locating the New Water Heater” section in this manual.
5. For California installation this water heater must be braced, anchored, or strapped to avoid falling or moving during an earthquake. See instructions for correct installation procedures. Instructions may be obtained from California Office of the State Architect, 400 P Street, Sacramento, CA 95814.
6. Massachusetts Code requires this water heater to be installed in accordance with Massachusetts 248-CMR 2.00: State Plumbing Code and 248-CMR 5.00.
7. Complies with SCAQMD rule #1121 and districts having equivalent NOx requirements.

TYPICAL INSTALLATION

GET TO KNOW YOUR WATER HEATER - GAS MODELS

- | | | |
|-----------------------------|-------------------------------------|--------------------------------|
| A Vent Pipe | J Drip Leg (Sediment Trap) | S Flue Baffle |
| B Securing Clamp | K Inner Door | T Thermostat |
| C Anode | L Outer door | U Drain Valve |
| D Hot Water Outlet | M Union | V Pilot and Main Burner |
| E Outlet | N Inlet Water Shut-off Valve | W Flue |
| F Roof Jack | O Cold Water Inlet | X Air Duct Assembly |
| G Gas Supply | P Inlet Nipple | Y Drain Pan |
| H Manual Gas Shut-off Valve | Q Temperature-Pressure Relief Valve | Z Thermostat Shield (optional) |
| I Ground Joint Union | R Rating Plate | ZZ Piezo Igniter |

* INSTALL IN ACCORDANCE WITH LOCAL CODES.

* DRIP LEG AS REQUIRED BY LOCAL CODES.

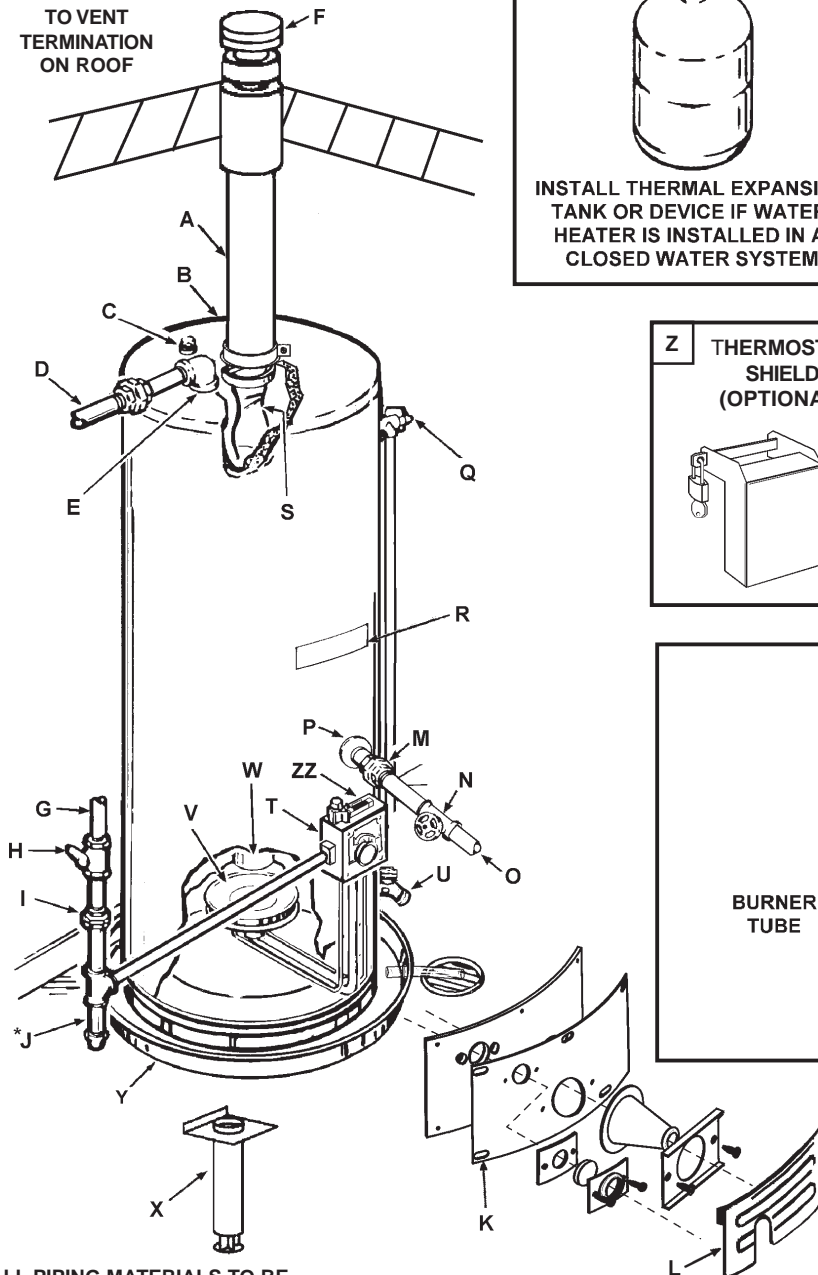

* ALL PIPING MATERIALS TO BE SUPPLIED BY CUSTOMERS.

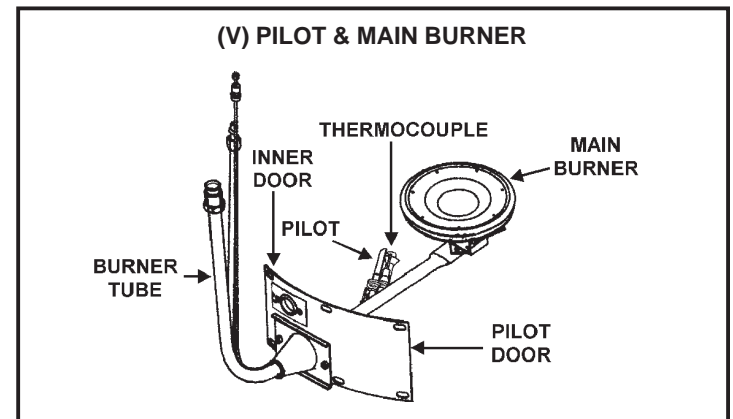
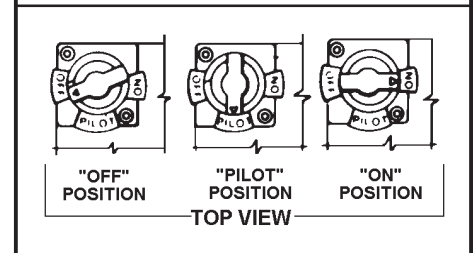
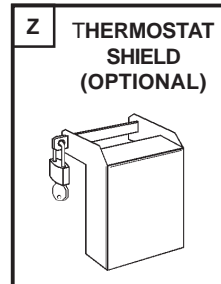
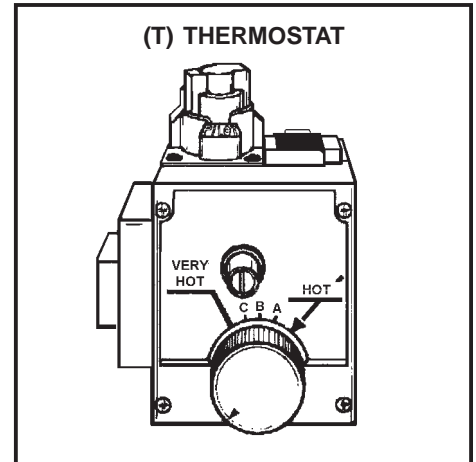
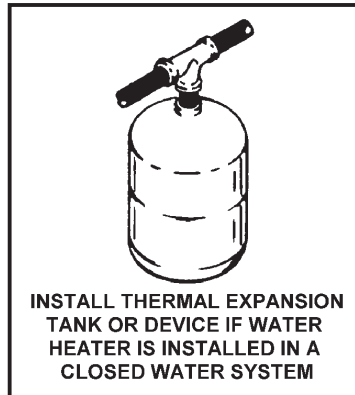
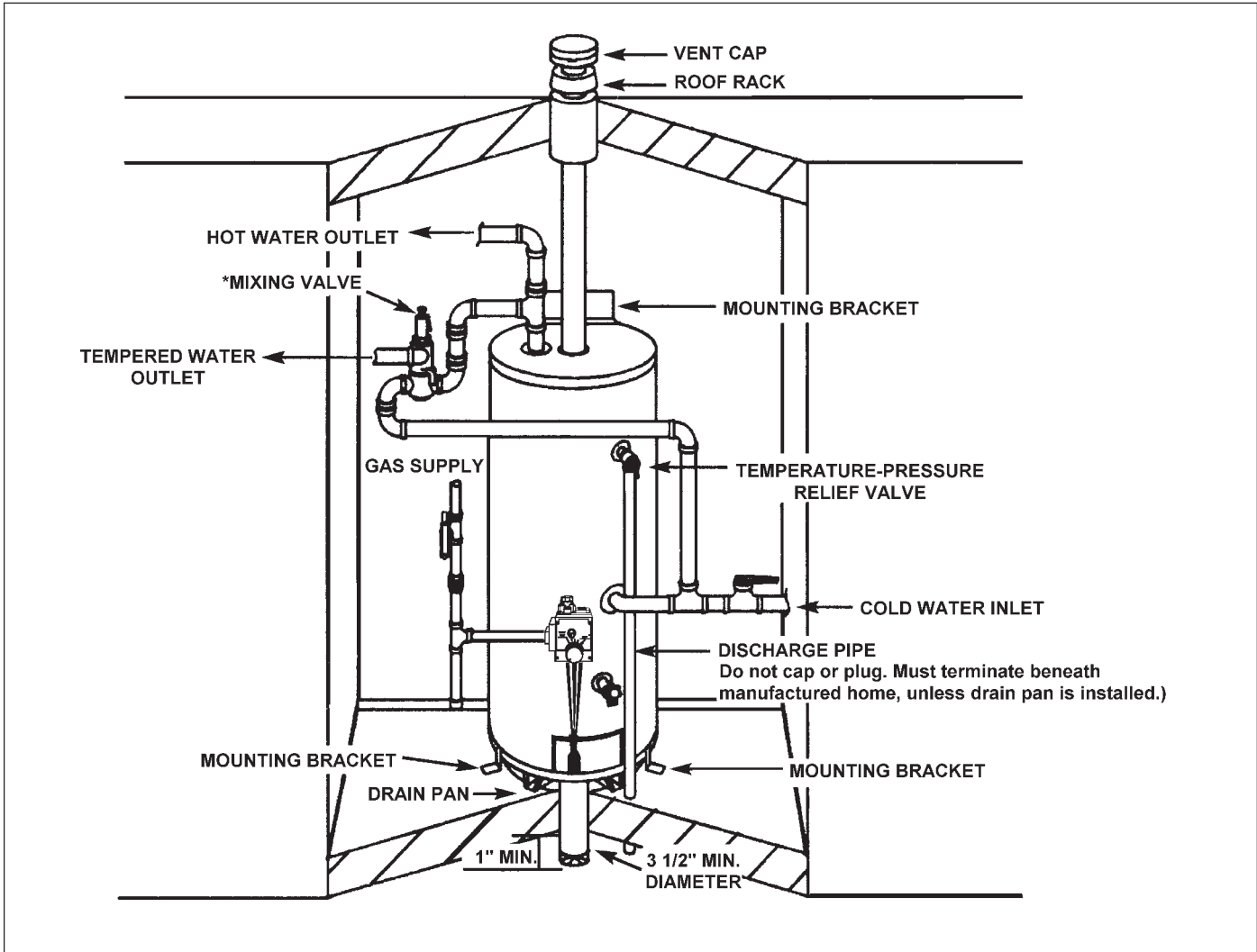

FIGURE 1.

TYPICAL INSTALLATION



* MIXING VALVE USAGE

FIGURE 2.

This appliance has been design certified as complying with American National Standard/CSA Standard ANSI Z21.10.1 • CSA 4. 1 for water heaters and is considered suitable for:

Water (Potable) Heating: All models are considered suitable for water (potable) heating.

	<p>Water temperature over 125°F (52°C) can cause severe burns instantly resulting in severe injury or death.</p> <p>Children, the elderly, and the physically or mentally disabled are at highest risk for scald injury.</p> <p>Feel water before bathing or showering.</p> <p>Temperature limiting valves are available.</p> <p>Read instruction manual for safe temperature setting.</p>
--	--

HOTTER WATER CAN SCALD:

Water heaters are intended to produce hot water. Water heated to a temperature which will satisfy space heating, clothes washing, dish washing, and other sanitizing needs can scald and permanently injure you upon contact. Some people are more likely to be permanently injured by hot water than others. These include the elderly, children, the infirm, or physically/mentally handicapped. If anyone using hot water in your home fits into one of these groups or if there is a local code or state law requiring a certain temperature water at the hot water tap, then you must take special precautions. In addition to using the lowest possible temperature setting that satisfies your hot water needs, a means such as a *Mixing Valve, shall be used at the hot water taps used by these people or at the water heater. Mixing valves are available at plumbing supply or hardware stores. Consult a Qualified Installer or Service Agency. Follow mixing valve manufacturer's instructions for installation of the valves. Before changing the factory setting on the thermostat, read the "Temperature Regulation" section in this manual, see Figures 36 and 37.

LOCATING THE NEW WATER HEATER

FACTS TO CONSIDER ABOUT THE LOCATION

Whether replacing an old water heater or putting the water heater in a new location, the following critical points must be observed.

This manufactured home gas-fired water heater is for use in a manufactured home. You should carefully choose an indoor location for the new water heater, because the placement is a very important consideration for the safety of your occupants in the building and for the most economical use of the appliance. **This water heater is for use only in a manufactured home and not intended for outdoor installation.**

This water heater has been designed and certified as a direct vent (sealed combustion) unit and no draft diverter is to be used.

Minimum clearances between the water heater and combustible and noncombustible construction are 0" from sides, 0" from back, 4" from front of jacket to closet door and 27" from top of jacket to combustible material. Minimum vent clearances: 6". Provide 24" front clearance for servicing and adequate clearance between the jacket top and ceiling for servicing the flue area.

The combustion and ventilation air flow must not be obstructed.

Combustion air must be supplied from outside the manufactured home by way of the furnished 3" diameter (30 and 40 Gallon) or 4" diameter (50 Gallon) air intake duct assembly. A 3 1/2" diameter (30 and 40 Gallon) or 4 1/2" diameter (50 Gallon) floor opening below the water heater is required to accommodate the air intake duct assembly. Weight of the water heater on duct gasket seals the water heater to air intake duct assembly.

When a manufactured home is skirted, an air intake opening with a minimum free area of 32 square inches must be provided in the skirt. If the opening is covered by louvers or screen, the total free area must be 32 square inches. Other gas fired appliance in the home will require additional free air openings; consult these manufacturers for correct sizing, see Figure 3.

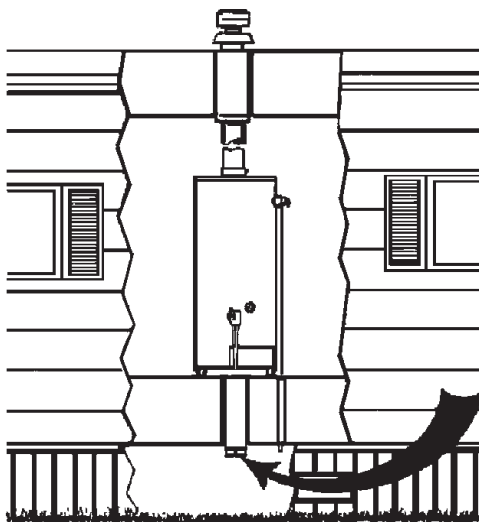

FIGURE 3.

If the manufactured home is installed over a basement or crawlspace, combustion air must be supplied from outside the manufactured home. The combustion air intake piping can be 3" PVC for 30 and 40 gallon models and 4" PVC for 50 gallon models. The air intake piping cannot exceed a total of 30 feet including vertical and horizontal runs and

have no more than 3 elbows. All horizontal runs require adequate support at 3 1/2 feet intervals., see Figure 4.

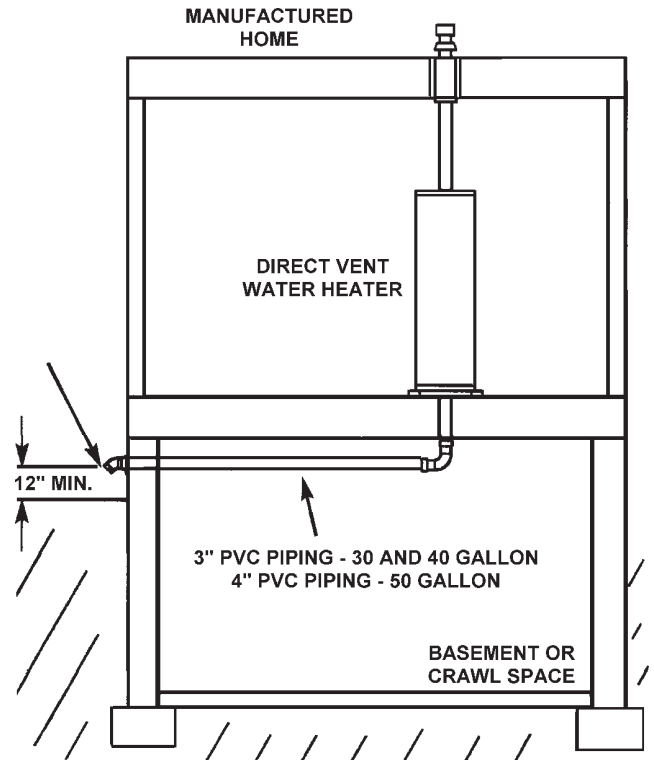

FIGURE 4.

The water heater should be secured to the floor and to the wall of the enclosure with the mounting brackets provided. For bracket location refer to Securing Water Heater to Floor and Wall" in the "Installing the New Water heater" section.

CAUTION

Property Damage Hazard

- All water heaters eventually leak
- Do not install without adequate drainage.

Installation of the water heater must be accomplished in such a manner that if the tank or any connections should leak, the flow will not cause damage to the structure. For this reason, it is not advisable to install the water heater in an attic or upper floor. When such locations cannot be avoided, a suitable drain pan should be installed under the water heater. Drain pans are available at your local hardware store. Such a drain pan must have a minimum length and width of at least 2 inches (51 mm) greater than the water heater dimensions and must be piped to an adequate drain. The pan must not restrict combustion air flow. When a drain pan is required, see installation instructions on page 9.

Water heater life depends upon water quality, water pressure and the environment in which the water heater is installed. Water heaters are sometimes installed in locations where leakage may result in property damage, even with the use of a drain pan piped to a drain. However, unanticipated damage can be reduced or prevented by a leak detector or water shut-off device used in conjunction with a piped drain pan.

These devices are available from some plumbing supply wholesalers and retailers, and detect and react to leakage in various ways:

- Sensors mounted in the drain pan that trigger an alarm or turn off the incoming water to the water heater when leakage is detected.
- Sensors mounted in the drain pan that turn off the water supply to the entire home when water is detected in the drain pan.
- Water supply shut-off devices that activate based on the water pressure differential between the cold water and hot water pipes connected to the water heater.
- Devices that will turn off the gas supply to a gas water heater while at the same time shutting off its water supply.

⚠ DANGER

Fire or Explosion Hazard

- Do not store or use gasoline or other flammable vapors and liquids in the vicinity of this or any other appliance.



INSTALLATIONS IN AREAS WHERE FLAMMABLE LIQUIDS (VAPORS) ARE LIKELY TO BE PRESENT OR STORED (GARAGES, STORAGE AND UTILITY AREAS, ETC.): Flammable liquids (such as gasoline, solvents, propane [LP or butane, etc.] and other substances such as adhesives, etc.) emit flammable vapors which can be ignited by a gas water heater's pilot light or main burner. The resulting flashback and fire can cause death or serious burns to anyone in the area, as well as property damage. If installation in such areas is your only option, then the installation must be accomplished in a way that the pilot flame and main burner flame are elevated from the floor at least 18 inches. While this may reduce the chances of flammable vapors, from a floor spill being ignited, gasoline and other flammable substances should never be stored or used in the same room or area containing a gas water heater or other open flame or spark producing appliance. NOTE: Flammable vapors may be drawn by air currents from other areas of the structure to the appliance.

Also, the water heater must be located and/or protected so it is not subject to physical damage by a moving vehicle.



⚠ WARNING

Fire Hazard

For continued protection against risk of fire:

- Do not install water heater on carpeted floor.
- Do not operate water heater if flood damaged.

This water heater must not be installed directly on carpeting. Carpeting must be protected by metal or wood panel beneath the appliance extending beyond the full width and depth of the appliance by at least 3 inches (76.2 mm) in any direction, or if the appliance is installed in an

alcove or closet, the entire floor must be covered by the panel. Failure to heed this warning may result in a fire hazard.

⚠ WARNING

Fire or Explosion Hazard

Read instruction manual before installing, using or servicing water heater.

- Improper use may result in fire or explosion.
- Maintain required clearances to combustibles.



A gas water heater cannot operate properly without the correct amount of air for combustion. Provide ventilation and combustion air by means of an air intake duct assembly as stated in "Water Heater Installation". Never obstruct the flow of ventilation air. If you have any doubts or questions at all, call your gas supplier. Failure to provide the proper amount of combustion air can result in a fire or explosion and cause death, serious bodily injury, or property damage.

⚠ WARNING

Breathing Hazard - Carbon Monoxide Gas



- Install water heater in accordance with the instruction manual and NFPA 54.
- To avoid injury, combustion and ventilation air must be taken from outdoors.
- Do not place chemical vapor emitting products near water heater.

Breathing carbon monoxide can cause brain damage or death. Always read and understand instruction manual.

If this water heater will be used in beauty shops, barber shops, cleaning establishments, or self-service laundries with dry cleaning equipment, it is imperative that the water heater or water heaters be installed so that combustion and ventilation air be taken from outside these areas. Propellants of aerosol sprays and volatile compounds, (cleaners, chlorine based chemicals, refrigerants, etc.) in addition to being highly flammable in many cases, will also change to corrosive hydrochloric acid when exposed to the combustion products of the water heater. The results can be hazardous, and also cause product failure.

INSULATION BLANKETS

⚠ WARNING

Breathing Hazard - Carbon Monoxide Gas



- Do not obstruct water heater air intake with insulating blanket.
- Gas and carbon monoxide detectors are available.
- Install water heater in accordance with the instruction manual.

Breathing carbon monoxide can cause brain damage or death. Always read and understand instruction manual.

Insulation blankets are available to the general public for external use on gas water heaters but are not necessary with these products. The purpose of an insulation blanket is to reduce the standby heat loss encountered with storage tank heaters. Your water heater meets or exceeds the National Appliance Energy Conservation Act standards with respect to insulation and standby loss requirements, making an insulation blanket unnecessary.

Should you choose to apply an insulation blanket to this heater, you should follow these instructions (For identification of components mentioned below, see Figure 1). Failure to follow these instructions can restrict the air flow required for proper combustion, potentially resulting in fire, asphyxiation, serious personal injury or death.

- Do not apply insulation to the top of the water heater, as this will interfere with safe operation of the draft hood.

- Do not cover the outer door, thermostat or temperature & pressure relief valve.
- Do not allow insulation to come within 2" (50.8 mm) of the floor to prevent blockage of combustion air flow to the burner.
- Do not cover the instruction manual. Keep it on the side of the water heater or nearby for future reference.
- Do obtain new warning and instruction labels from the manufacturer for placement on the blanket directly over the existing labels.
- Do inspect the insulation blanket frequently to make certain it does not sag, thereby obstructing combustion air flow.

INSTALLING THE NEW WATER HEATER

WATER HEATER INSTALLATION

1. To locate the position of the 3 1/2" or 4 1/2" hole to be cut in the floor, see Figures 5 and 6.

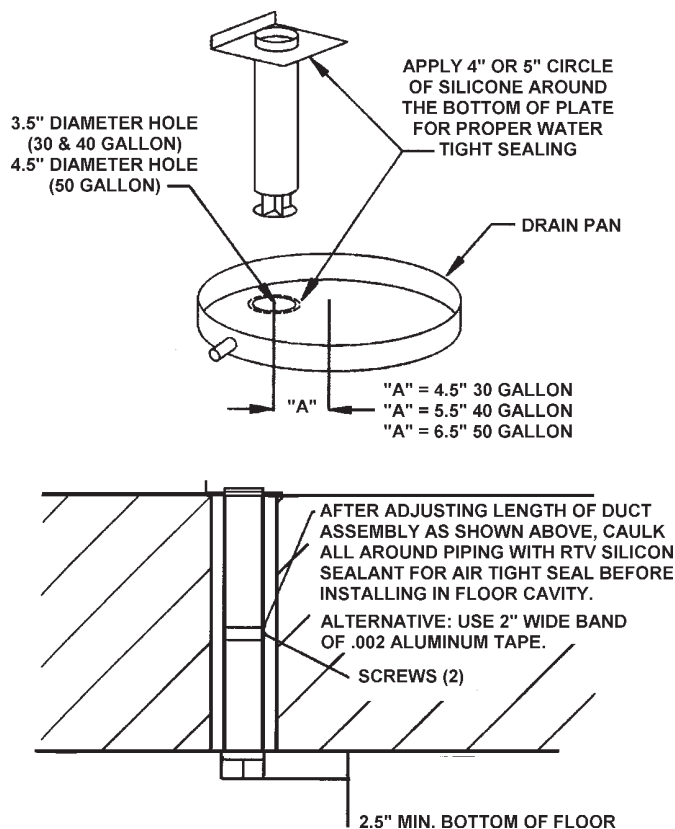

FIGURE 5.

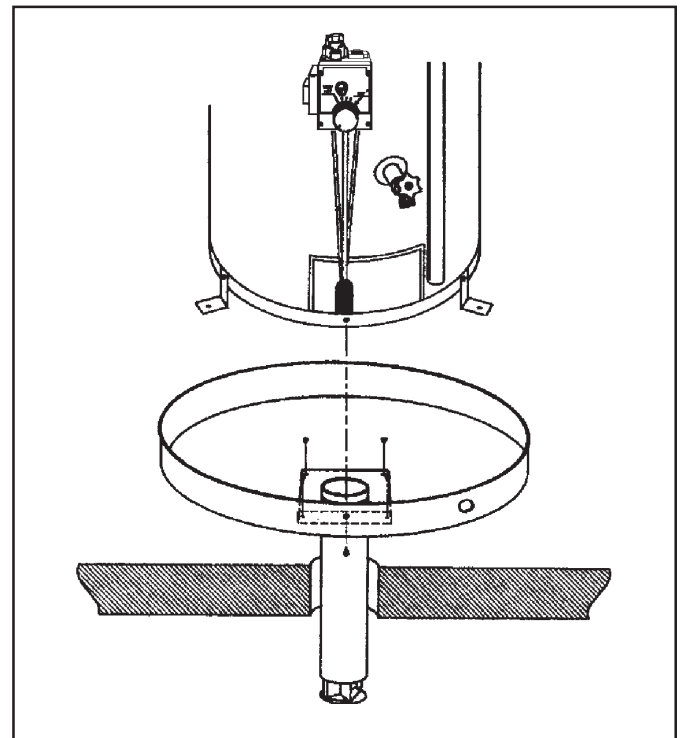

FIGURE 6.

2. If you have found that the water heater is being installed in an area which, if the water heater was to leak, would cause damage and have elected to install a drain pan refer to Figures 7, 8 and 9 on page 10. If you are not installing a drain pan go directly to the next step.

NOTE: Clearances from combustible or non combustible surface to jacket will change template dimensions.

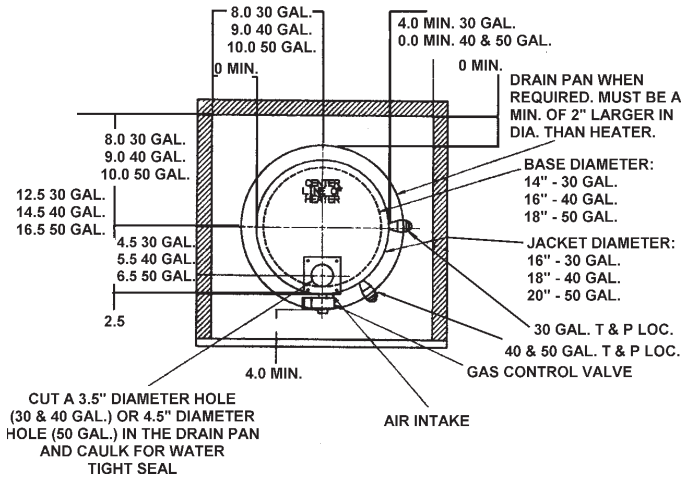
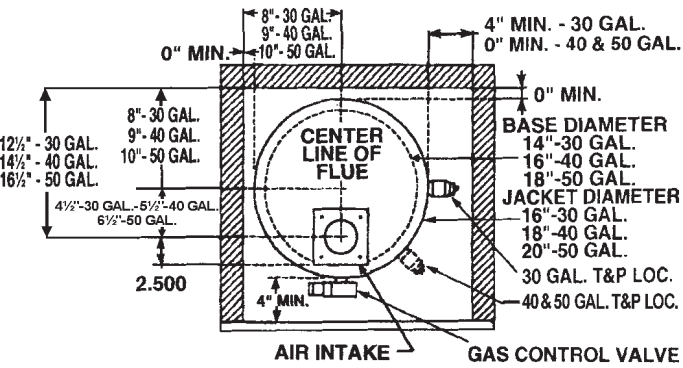
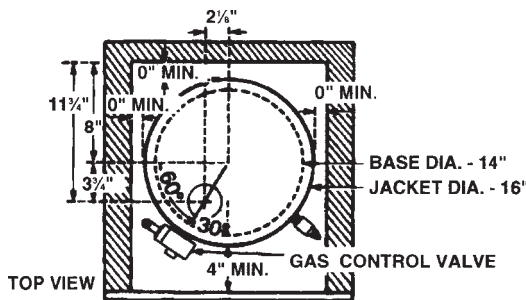

FIGURE 7.



DIRECTION IN WHICH WATER HEATER CAN BE PLACED WHEN INCREASED SIDE CLEARANCE IS AVAILABLE

FIGURE 8.



DIRECTION IN WHICH WATER HEATER MUST BE PLACED WHEN MINIMUM CLEARANCES ARE USED (30 GALLON ONLY)

FIGURE 9.

3. Insert the duct assembly as shown in Figure 10 with lip facing forward, and using only nails, secure the duct assembly to the floor.

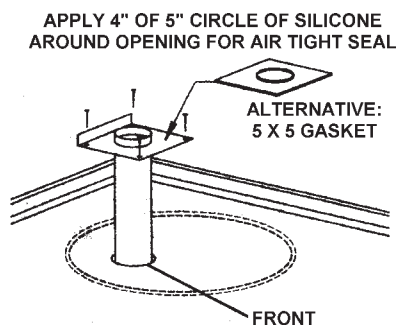

FIGURE 10.

4. Set the water heater in place against the lip of the duct assembly as shown in Figure 11.

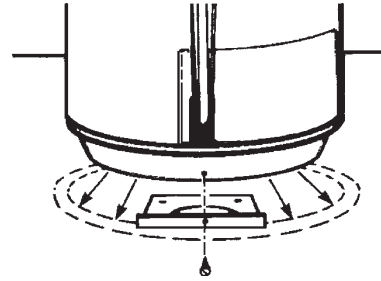

FIGURE 11.

5. Secure the water heater to the duct assembly using the screw provided.

NOTE: See pages 12 and 13 for installing an air intake through an outside wall when the manufactured home is located over a basement or crawl space.

SECURING WATER HEATER TO FLOOR AND WALL

The water heater must be secured to the floor and to the wall of the enclosure with the three mounting brackets and screws packaged in the carton with the water heater. The two small brackets stamped #0110064 are used to attach the water heater to the floor and the one large bracket #0110063 is used to secure the top of the water heater to the wall.

Because of installation variances these brackets can be located at any points around the circumference of the jacket. When the bracket locations are determined using the 1/8 inch drill bit for a pattern, drill only through the outer jacket of the water heater. Then using the screws provided, secure the bracket to the water heater, floor and wall, see Figure 12.

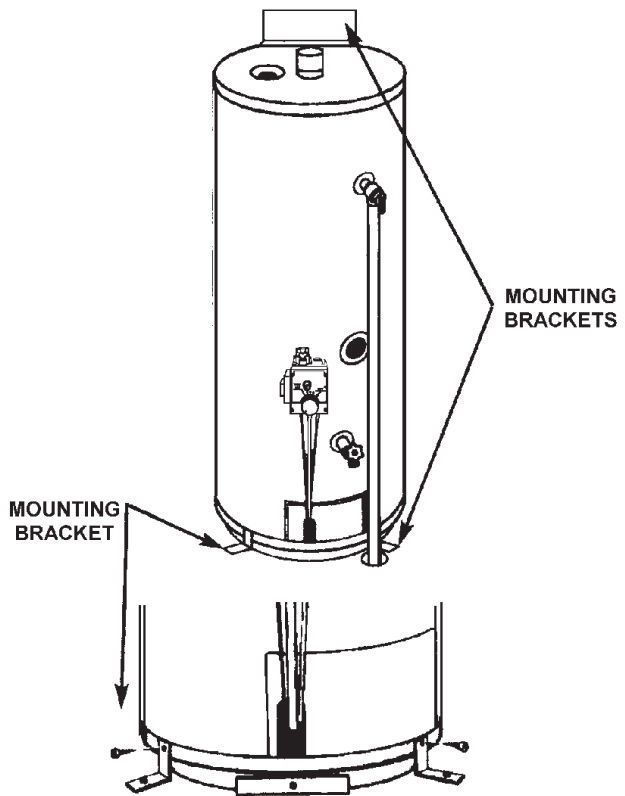

FIGURE 12.

ROOF JACK INSTALLATION

ROOF JACK KIT MODELS VENT KIT - 12 INCH (9002964), VENT KIT - 32 INCH (9002965), VENT KIT - 60 INCH (9002966) AND VENT KIT - 95 INCH (9002967)

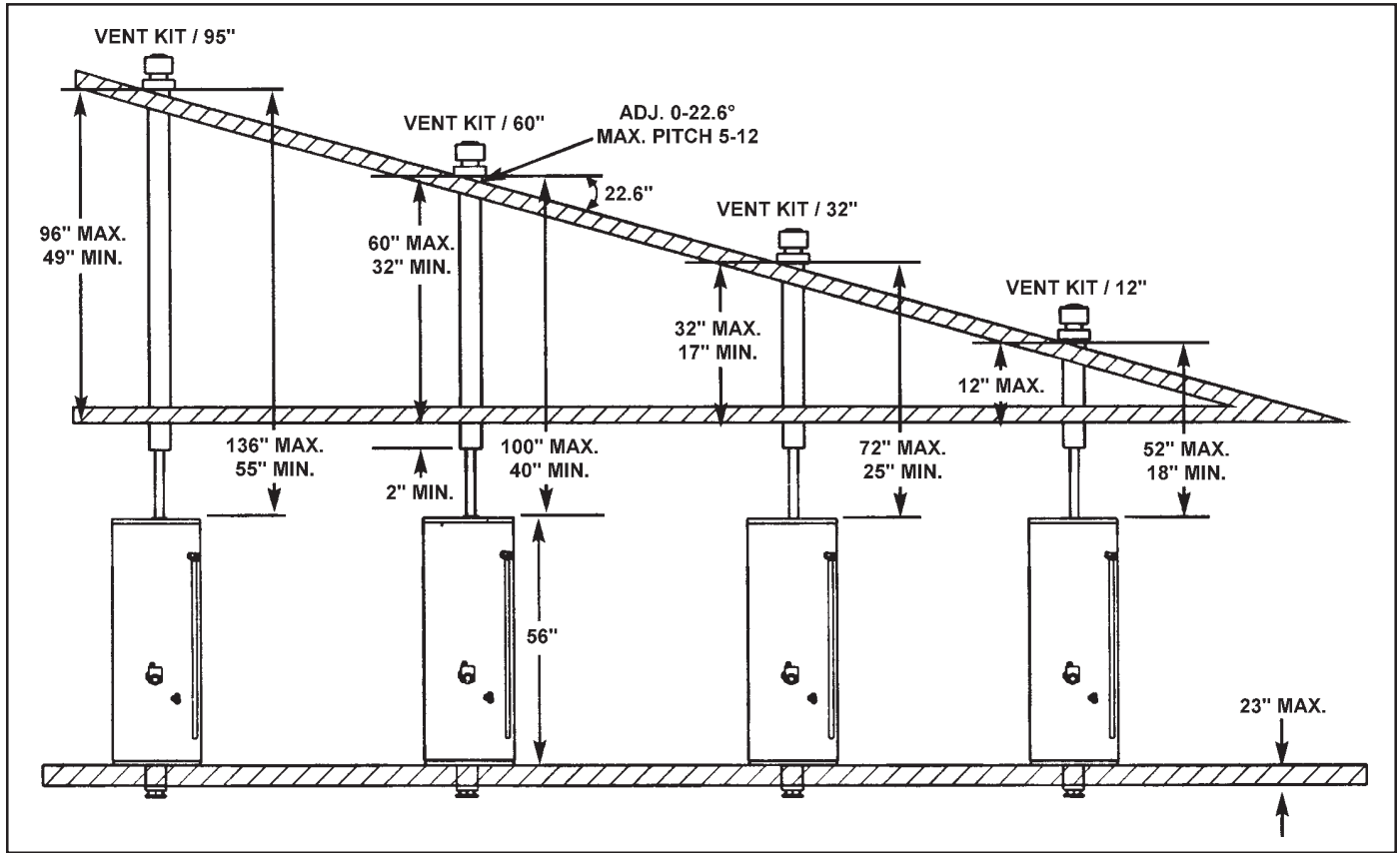

FIGURE 13.

1. Cut 5 1/2" diameter holes through the roof and ceiling directly in line with the flue connection on top of the water heater. For a sloped roof, the roof hole may have to be enlarged to allow the roof jack to be installed vertically.
2. Telescope down the flue pipe in the roof jack assembly to a length that will project at least 6" below the finished ceiling before installing the roof jack assembly.
3. Telescope down the outer pipe of the roof jack assembly to a length that will project at least 2" below the finished ceiling before installing the roof jack assembly, see Figure 14.
4. Ease the roof jack assembly through the roof and ceiling openings. The roof jack flashing tilts up to 22.6° degrees for use on a sloping roof.
5. Use sealant or caulk on the roof to seal under flashing of the roof jack assembly. Use roof nails or screws on wood construction or sheet metal screws on metal roofs (nails and screws not provided), see Figure 15.

NOTE: Flue pipe joints have silicone seals that must remain in place. A soapy water solution sprayed around the seal area will enable the flue pipe and outer pipe below to telescope more freely.

3. Telescope down the outer pipe of the roof jack assembly to a length that will project at least 2" below the finished ceiling before installing the roof jack assembly, see Figure 14.

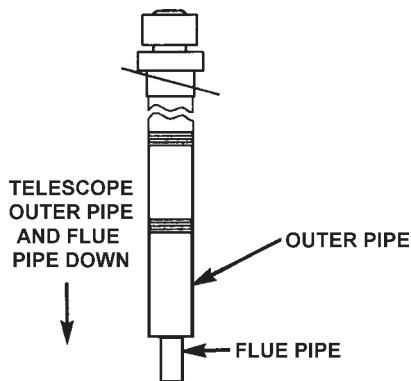

FIGURE 14.

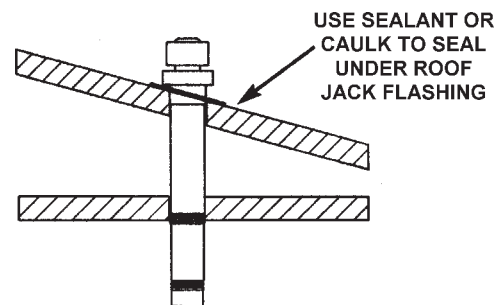

FIGURE 15.

NOTE: An optional Roof jack Extension Pipe (9002588) is required when the roof pitch is 5 1/2" or greater, or where local codes require the roof jack cap (outlet) terminate above the peak of the roof.

6. Remove the paper backing from the 1 1/2" x 9 3/4" woven tape seal (found attached to the heater top) and apply the seal around the flue collar of the water heater, see Figure 16 on page 12.

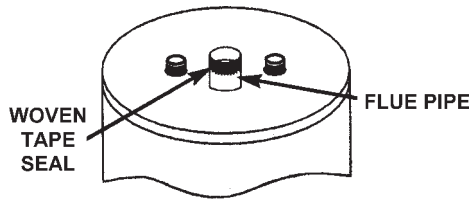

FIGURE 16.

7. Extend the flue pipe down close to the water heater flue collar, see Figure 17.

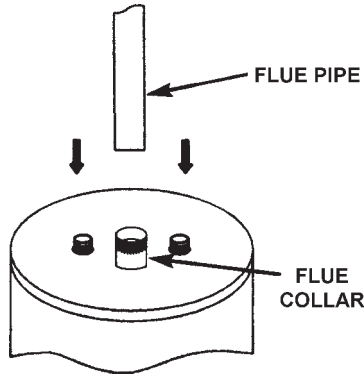

FIGURE 17.

8. Slide the securing clamp over the bottom of the flue pipe and pull the pipe down over the flue collar. Locate vent securing clamp in top and secure clamp with sheet metal screw. Tighten nut and bolt clamp until flue pipe is tight in clamp, see Figure 18.

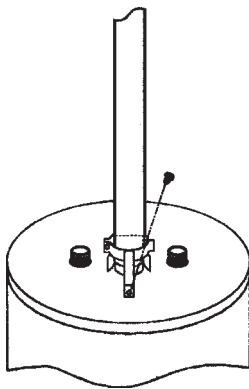

FIGURE 18.

NOTE: All joints for vent piping between roof jack and water heater are sealed from the manufacturer. No additional sealing of vent pipe is necessary.

MANUFACTURED HOME INSTALLED OVER BASEMENT OR CRAWLSPACE - AIR INTAKE THROUGH AN OUTSIDE WALL

ALL 30 AND 40 GALLON MODELS

3" PVC Schedule 40 intake air vent piping:
Optional Kit No. 9002986 contains a 3" PVC Schedule 40-45° vent cap with screen and two 3" wall collars.

ALL 50 GALLON MODELS

4" PVC Schedule 40 intake air vent piping:
Optional Kit no. 9002987 contains a 4" PVC Schedule 40-45° vent cap with screen and two 4" wall collars.

ALL MODELS

1. PVC, ABS or CPVC Schedule 40 piping and fittings are acceptable materials for the intake air vent system.
2. The intake air vent system must terminate horizontally to the outdoors.
3. Remove the screws which attach the wind baffle to the existing metal air intake vent pipe underneath the home. Discard the wind baffle and screws, see Figure 19.

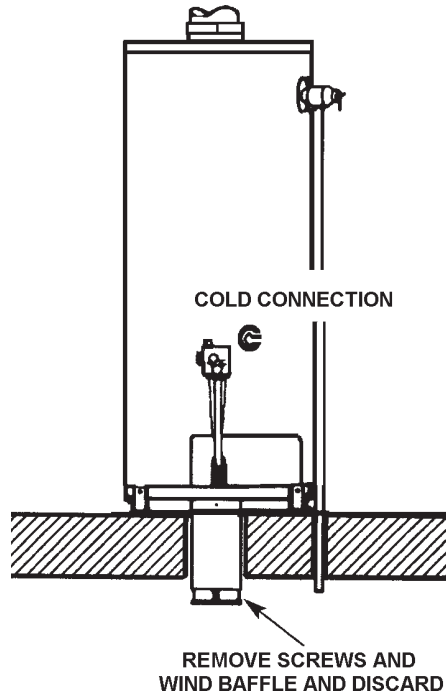

FIGURE 19.

4. Attach a 3" or 4" PVC street elbow to the metal air intake vent using 3 sheet screws. Continue PVC piping to outside wall and terminate with vent cap and screen, see Figure 20.

3" size - 30 and 40 gallon models.
4" size - 50 gallon models.

See pages 13 and 14 for cementing instructions

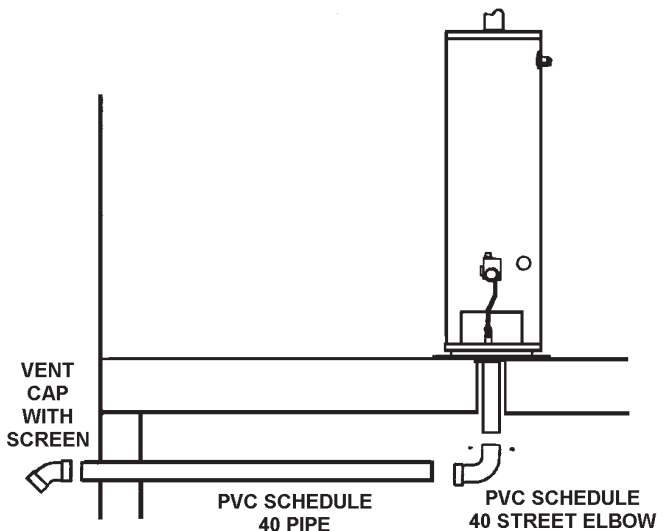

FIGURE 20.

NOTE: Vent cap must be located a minimum of 12" above the ground.

- Vertical and horizontal runs must be securely supported at 3 1/2 Foot intervals, see Figure 21.

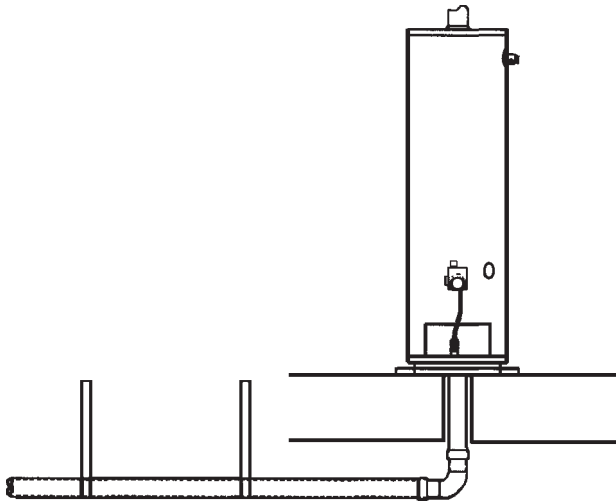

FIGURE 21.

- The intake air vent piping can be installed with no more than 3 elbows, see Figure 22.

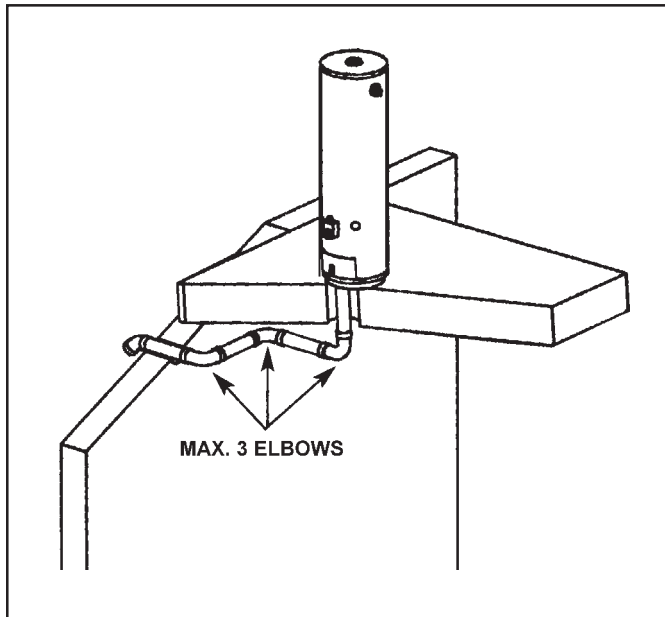

FIGURE 22.

CUTTING OPENING THROUGH AN OUTSIDE WALL AND COLLAR INSTALLATION

Determine the location of the opening in the wall and cut a 3 3/4" hole (30 & 40 Gallon) or 4 3/4" hole (50 Gallon) through an outside wall.

The 3" or 4" PVC, ABS or CPVC Schedule 40 vent pipe can be run from the water heater through the wall or from the wall to the water heater, whichever is most convenient. The vent pipe must extend a minimum of 1 1/2" through the exterior wall. Note that the inside collar must be slipped over the vent piping before locating the pipe through the wall. Before securing the inside and outside collars to the wall, use a silicone sealer between pipe and opening to insure a water and air tight seal, see Figure 23.

INSTALLATION SHOWING USE OF PVC, ABS OR CPVC PIPE

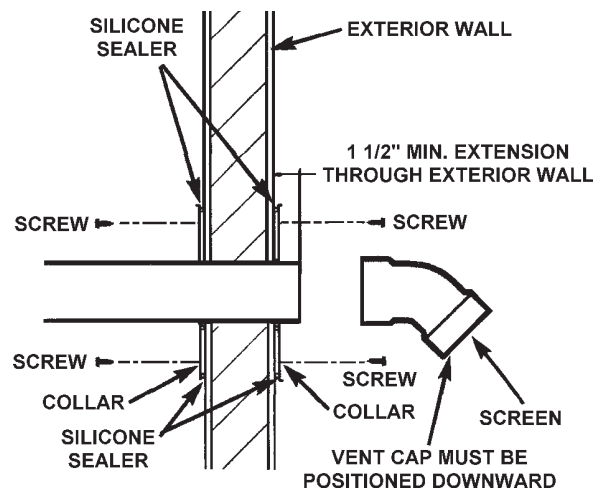

FIGURE 23.

NOTE: Wall collars are for aesthetic purposes and are not required for the heater to operate.

CEMENTING PVC, ABS OR CPVC PIPE AND FITTINGS

Read and observe all safety information printed on primer, cleaner, and cement containers.

Primer, cleaner, and cements are extremely flammable. They are harmful or fatal if swallowed. The vapors are harmful. They may irritate eyes and skin and can be absorbed through the skin.

Always store primer, cleaner, and cements in cool, dry, well ventilated places. Keep containers closed. Use them in well ventilated areas. Wear impervious clothing while handling. Do not smoke, eat, or drink while handling. Wash thoroughly after handling and before eating. Wear eye protection when handling. If swallowed, drink water, do not induce vomiting, and call a physician or poison control center immediately. If inhaled, get fresh air and seek medical attention if ill feelings persist. In case of eye and skin contact, immediately flush with plenty of water for 15 minutes and seek medical attention if irritation persists. **KEEP OUT OF REACH OF CHILDREN.**

All primers, cleaners, and cements must meet all local codes and applicable standards of the American Society For Testing Materials Standards.

Before using primers, cleaners and cements, stir or shake, making sure contents are liquid. Do not use if found to be lumpy or jelly-like.

- Cut pipe ends squarely removing all burrs and dirt.
- Dry fit pipe and fittings to be connected for proper fit.
- Clean pipe and fitting with primer/cleaner.
- Apply a thin coat of cement to fitting, avoiding puddling inside.
- Apply a liberal coat of cement to pipe leaving no voids.
- QUICKLY** assemble parts while cement is fluid! If you wait too long, recoat pipes.
- Push pipe completely into socket of fitting, turning as it goes until it bottoms.
- Hold pipe and fitting together for 30 seconds. Then carefully clean off excess with a cloth. Allow connections a sufficient time to cure before disturbing.
- Remember that vent pipes must be adequately and securely supported.

APPROXIMATE SETTING TIME FOR 2 1/2" TO 4" PIPE JOINTS

	MOVEMENT OF JOINT	COMPLETE SET
90°F TO 150°F	3/4HR.	8HRS.
50°F TO 90°F	1 HR.	15 HRS.
0°F TO 50°F	1 1/3 HR.	18 HRS.

WATER PIPING

⚠ DANGER

Water temperature over 125°F (52°C) can cause severe burns instantly resulting in severe injury or death.

Children, the elderly, and the physically or mentally disabled are at highest risk for scald injury.

Feel water before bathing or showering.

Temperature limiting valves are available.

Read instruction manual for safe temperature setting.

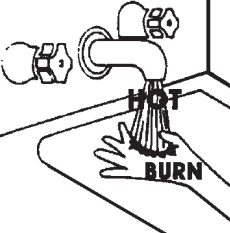

HOTTER WATER CAN SCALD:

Water heaters are intended to produce hot water. Water heated to a temperature which will satisfy space heating, clothes washing, dish washing, cleaning and other sanitizing needs can scald and permanently injure you upon contact. Some people are more likely to be permanently injured by hot water than others. These include the elderly, children, the infirm, or physically/mentally handicapped. If anyone using hot water in your home fits into one of these groups or if there is a local code or state law requiring a certain temperature water at the hot water tap, then you must take special precautions. In addition to using the lowest possible temperature setting that satisfies your hot water needs, a means such as a *mixing valve, shall be used at the hot water taps used by these people or at the water heater, see Figure 2. Valves for reducing point of use temperature by mixing cold and hot water are also available. Consult a Qualified Installer or Service Agency. Follow manufacturer's instructions for installation of the valves. Before changing the factory setting on the thermostat, read the "Temperature Regulation" section in this manual.

⚠ WARNING

Toxic Chemical Hazard

- Do not connect to non-potable water system.

This water heater shall not be connected to any heating systems or component(s) used with a non-potable water heating appliance.

Toxic chemicals, such as those used for boiler treatment shall not be introduced into this system.

Water supply systems may, because of such events as high line pressure, frequent cut-offs, the effects of water hammer among others, have installed devices such as pressure reducing valves, check valves, back flow preventers, etc. to control these types of problems. When these devices are not equipped with an internal by-pass, and no other measures are taken, the devices cause the water system to be closed. As water is heated, it expands (thermal expansion) and closed systems do not allow for the expansion of heated water.

The water within the water heater tank expands as it is heated and increases the pressure of the water system. If the relieving point of the water heater's temperature-pressure relief valve is reached, the valve will relieve the excess pressure. **The temperature-pressure relief valve is not intended for the constant relief of thermal expansion.** This is an unacceptable condition and must be corrected. It is recommended that any devices installed which could create a closed system have a by-pass and/or the system have an expansion tank to relieve the pressure built by thermal expansion in the water system. Expansion tanks are available for ordering through a local plumbing contractor. Contact the local water supplier and/or a service agency for assistance in controlling these situations.

NOTE: To protect against untimely corrosion of hot and cold water fittings, it is strongly recommended that di-electric unions or couplings be installed on this water heater when connected to copper pipe.

CAUTION

Property Damage Hazard

- Avoid water heater damage.
- Install thermal expansion tank if necessary.
- Do not apply heat to cold water inlet.
- Contact qualified installer or service agency.

Figure 24 shows the typical attachment of the water piping to the water heater. The water heater is equipped with 3/4 inch NPT water connections.

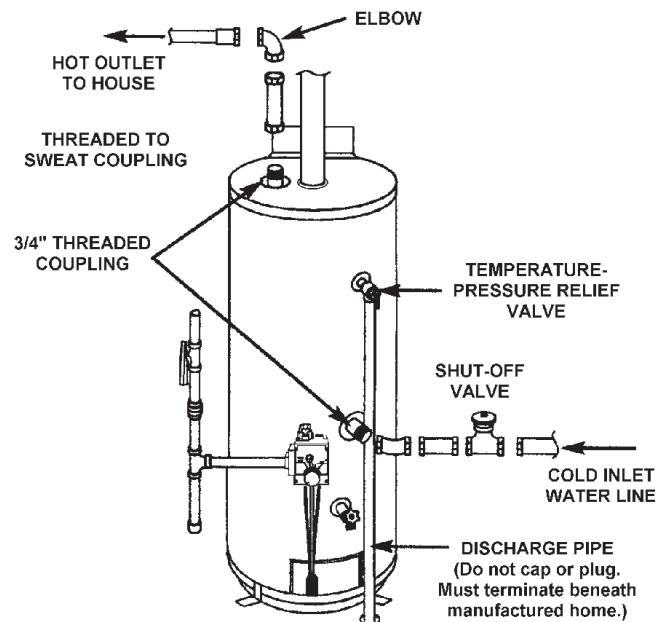

FIGURE 24.

T & P VALVE AND PIPE INSULATION

Remove insulation for T&P Valve and pipe connections from carton.

Fit pipe insulation over the hot water line. Make sure that the insulation is against the top cover of the heater.

Fit T&P Valve insulation over valve. Make sure that the insulation does not interfere with the lever of the T&P valve.

Secure all insulation using tape.

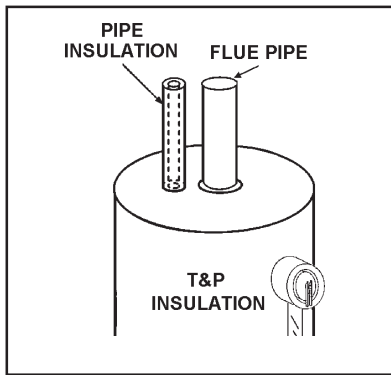

FIGURE 25.

WATER PIPING PRESSURE TEST

<h1>⚠ WARNING</h1> <h2>Air Pressure Hazard</h2>
<ul style="list-style-type: none"> • If water piping system is to be air pressure tested, the water heater must be disconnected from the water piping system. • Failure to disconnect the water heater during air pressure testing of the water system could result in DEATH, SERIOUS BODILY INJURY, OR PROPERTY DAMAGE.

This section is only for the manufacturer installing the water heater when the installation is to comply with H.U.D. Standards.

When testing the water ways, H.U.D. Standards state:

“Water distribution system. All water piping in the water distribution system shall be subjected to a pressure test. The test shall be made by subjecting the system to air or water at 100 psi for 15 minutes without loss of pressure. **When air pressure is used, the water heater shall not be connected during the test**”.

NOTE: If water piping system is to be air pressure tested, the water heater must be disconnected from the water piping system. Failure to disconnect the water heater during air pressure testing of water piping system could result in **DEATH, SERIOUS BODILY INJURY, OR PROPERTY DAMAGE.**

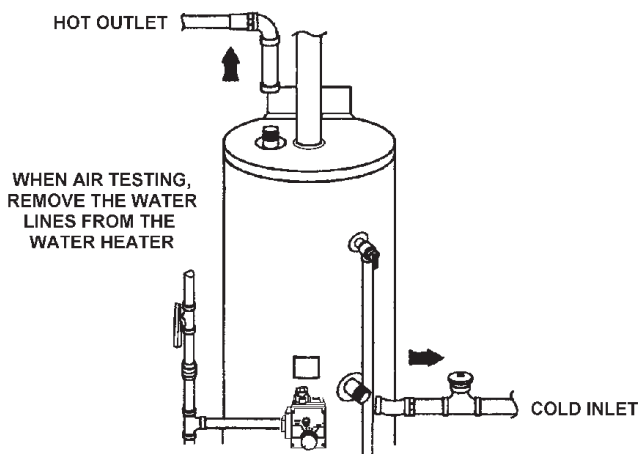

FIGURE 26.

TEMPERATURE-PRESSURE RELIEF VALVE

	<h1>⚠ WARNING</h1> <h2>Explosion Hazard</h2>
	<ul style="list-style-type: none"> • Temperature-pressure relief valve must comply with ANSI Z21.22 and ASME code. • Properly sized temperature-relief valve must be installed in opening provided. • Can result in overheating and excessive tank pressure. • Can cause serious injury or death.

This heater is provided with a properly certified combination temperature - pressure relief valve by the manufacturer.

The valve is certified by a nationally recognized testing laboratory that maintains periodic inspection of production of listed equipment of materials as meeting the requirements for Relief Valves and Automatic Gas Shut-off Devices for Hot Water Supply Systems, ANSI Z21.22 • CSA 4.4, and the code requirements of ASME.

If replaced, the valve must meet the requirements of local codes, but not less than a combination temperature and pressure relief valve certified as indicated in the above paragraph.

The valve must be marked with a maximum set pressure not to exceed the marked hydrostatic working pressure of the water heater (150 psi = 1,035 kPa) and a discharge capacity not less than the water heater input rate as shown on the model rating plate.

For safe operation of the water heater, the relief valve must not be removed from its designated opening nor plugged.

The temperature-pressure relief valve must be installed directly into the fitting of the water heater designed for the relief valve. Position the valve downward and provide tubing so that any discharge will exit only at any distance below the structural floor. Be certain that no contact is made with any live electrical part. The discharge opening must not be blocked or reduced in size under any circumstances. Excessive length, over 30 feet (9.14 m), or use of more than four elbows can cause restriction and reduce the discharge capacity of the valve, see Figure 27.

No valve or other obstruction is to be placed between the relief valve and the tank. Do not connect tubing directly to discharge drain unless a 6 inch air gap is provided. To prevent bodily injury, hazard to life, or property damage, the relief valve must be allowed to discharge water in quantities should circumstances demand. If the discharge pipe is not connected to a drain or other suitable means, the water flow may cause property damage.

<h1>CAUTION</h1> <h2>Water Damage Hazard</h2>
<ul style="list-style-type: none"> • Temperature-pressure relief valve discharge pipe must terminate at adequate drain.

The Discharge Pipe:

- Shall not be smaller in size than the outlet pipe size of the valve, or have any reducing couplings or other restrictions.

- Shall not be plugged or blocked.
- Shall be of material listed for hot water distribution.
- Shall be installed so as to allow complete drainage of both the temperature-pressure relief valve, and the discharge pipe.
- Shall terminate at an adequate drain.
- Shall not have any valve between the relief valve and tank.

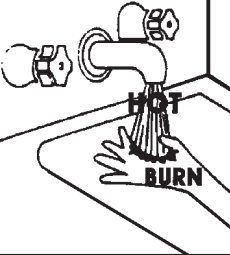

⚠ DANGER Water temperature over 125°F (52°C) can cause severe burns instantly resulting in severe injury or death.

Children, the elderly, and the physically or mentally disabled are at highest risk for scald injury.

Feel water before bathing or showering.

Temperature limiting valves are available.

Read instruction manual for safe temperature setting.

The temperature-pressure relief valve must be manually operated at least once a year. Caution should be taken to ensure that (1) no one is in front of or around the outlet of the temperature-pressure relief valve discharge line, and (2) the water manually discharged will not cause any bodily injury or property damage because the water may be extremely hot.

If after manually operating the valve, it fails to completely reset and continues to release water, immediately close the cold water inlet to the water heater, follow the draining instructions, and replace the temperature-pressure relief valve with a new one.

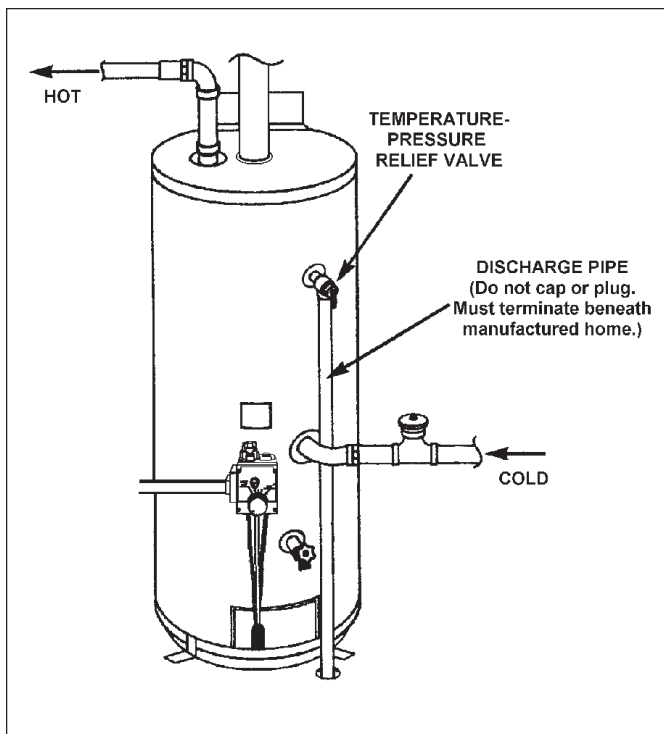

FIGURE 27.

FILLING THE WATER HEATER

CAUTION

Property Damage Hazard

- Avoid water heater damage.
- Fill tank with water before operating.

Never use this water heater unless it is completely full of water. To prevent damage to the tank, the tank must be filled with water. Water must flow from the hot water faucet before turning "ON" gas to the water heater.

To fill the water heater with water:

1. Close the water heater drain valve by turning the handle to the right (clockwise). The drain valve is on the lower front of the water heater.
2. Open the cold water supply valve to the water heater.
NOTE: The cold water supply valve must be left open when the water heater is in use.
3. To insure complete filling of the tank, allow air to exit by opening the nearest hot water faucet. Allow water to run until a constant flow is obtained. This will let air out of the water heater and the piping.
4. Check all water piping and connections for leaks. Repair as needed.

GAS PIPING



⚠ WARNING

Fire and Explosion Hazard

- Do not use water heater with any gas other than the gas shown on the rating plate.
- Excessive pressure to gas control valve can cause serious injury or death.
- Turn off gas lines during installation.
- Contact qualified installer or service agency.

Make sure the gas supplied is the same type listed on the model rating plate. The inlet gas pressure must not exceed 10.5" W.C. for natural gas and 13" W.C. for propane (L.P.) gas. The minimum inlet gas pressure shown on the rating plate is that which will permit firing at rated input.

If the gas control valve is subjected to pressures exceeding 1/2 pound per square inch (3.5 kPa), the damage to the gas control valve could result in a fire or explosion from leaking gas.

If the main gas line Shut-off serving all gas appliances is used, also turn "off" the gas at each appliance. Leave all gas appliances shut "off" until the water heater installation is complete.

A gas line of sufficient size must be run to the water heater. Consult the current edition of National Fuel Gas Code ANSI Z223.1/NFPA 54 and your gas supplier concerning pipe size.

There must be:

- A readily accessible manual shut off valve in the gas supply line serving the water heater, and
- A drip leg (sediment trap) ahead of the gas control valve to help prevent dirt and foreign materials from entering the gas control valve.
- A flexible gas connector or a ground joint union between the shut off valve and control valve to permit servicing of the unit.

Be sure to check all the gas piping for leaks before lighting the water heater. Use a soapy water solution, not a match or open flame. Rinse off soapy solution and wipe dry.

When installed at elevations above 5,000 feet (1524 m), input rating should be reduced at the rate of 4 percent for each 1,000 feet (305 m) above sea level which requires replacement of the burner orifice in accordance with National Fuel Gas Code ANSI Z223.1/NFPA54. Contact your local gas supplier for further information.

Failure to replace the standard orifice with a high altitude orifice when installed could result in improper and inefficient operation of the appliance, producing carbon monoxide gas in excess of safe limits, which could result in serious injury or death. Contact your gas supplier for any specific changes which may be required in your area.

	<h2 style="margin: 0;">⚠ WARNING</h2> <h3 style="margin: 0;">Fire and Explosion Hazard</h3>
	<ul style="list-style-type: none"> • Use joint compound or tape compatible with propane. • Leak test before operating heater. • Disconnect gas piping and shut-off valve before pressure testing system.

Use pipe joint compound or teflon tape marked as being resistant to the action of petroleum [Propane (L.P.)] gases.

The appliance and its gas connection must be leak tested before placing the appliance in operation.

The appliance and its individual Shut-off valve shall be disconnected from the gas supply piping system during any pressure testing of that system at test pressures in excess of 1/2 pound per square inch (3.5 kPa). It shall be isolated from the gas supply piping system by closing its individual manual Shut-off valve during any pressure testing of the gas supply piping system at test pressures equal to or less than 1/2 pound per square inch (3.5 kPa).

Connecting the gas piping to the gas control valve of the water heater can be accomplished by either of the two methods shown in Figures 28, 29 and 30.

SEDIMENT TRAPS

	<h2 style="margin: 0;">⚠ WARNING</h2> <h3 style="margin: 0;">Fire and Explosion Hazard</h3>
	<ul style="list-style-type: none"> • Contaminants in gas lines can cause fire or explosion. • Clean all gas piping before installation. • Install drip leg in accordance with NFPA 54.

A sediment trap shall be installed as close to the inlet of the water heater as practical at the time of water heater installation. The sediment trap shall be either a tee fitting with a capped nipple in the bottom outlet or other device recognized as an effective sediment trap. If a tee fitting is used, it shall be installed in conformance with one of the methods of installation shown in Figures 28, 29 and 30.

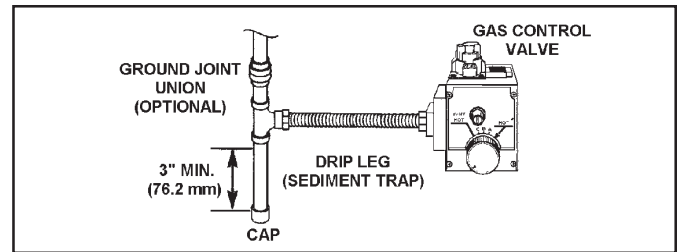

FIGURE 28. GAS PIPING WITH FLEXIBLE CONNECTOR.

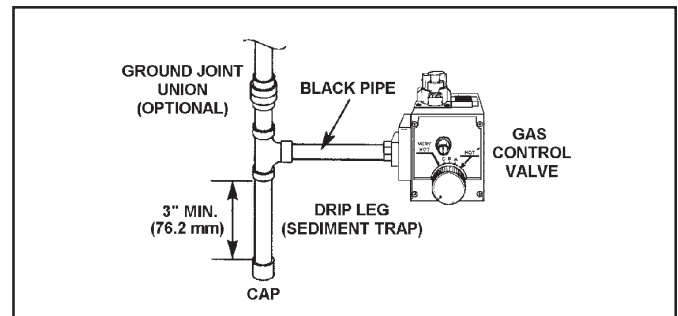

FIGURE 29. GAS PIPING WITH ALL BLACK IRON PIPE TO GAS CONTROL.

ALTERNATIVE SEDIMENT TRAP LOCATION

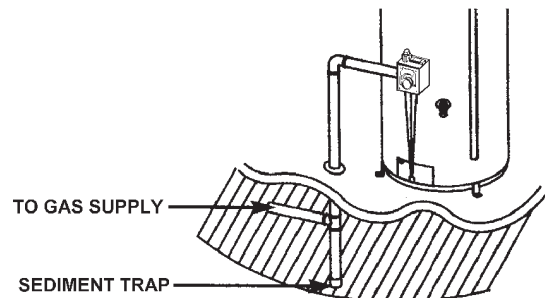

FIGURE 30.

Contaminants in the gas lines may cause improper operation of the gas control valve that may result in fire or explosion. Before attaching the gas line be sure that all gas pipe is clean on the inside. To trap any dirt or foreign material in the gas supply line, a drip leg (sometimes called a sediment trap) must be incorporated in the piping. The drip leg must be readily accessible. Install in accordance with the "Gas Piping" section. Refer to the current edition of the National Fuel Gas Code, ANSI Z223.1/ NFPA54.

FUEL CONVERSION INSTRUCTIONS FROM NATURAL GAS TO PROPANE (L.P.) GAS

This water heater has been factory equipped to operate with the type gas indicated in the "EQUIPPED FOR" area of the model rating plate located near the gas control valve. The indicated gas may be either Natural or Propane (L.P.). By following the conversion instructions in this manual or the instructions near the gas control valve, the water heater must be converted if it is to be used with the opposite gas. DO NOT USE THIS WATER HEATER WITH ANY GAS OTHER THAN THE ONE LISTED ON THE MODEL RATING PLATE. Failure to use the correct gas can cause problems which can result in DEATH, SERIOUS BODILY

INJURY, OR PROPERTY DAMAGE. If you have any questions or doubts consult your gas supplier or gas company.

Read and follow detailed conversion instructions located on the water heater and also in the instruction manual in their entirety before starting the conversion.

Conversion kit with necessary parts are in a bag attached to the drain valve.

FOR 30 GALLON HEATER:

Orifice size: #40 for Natural / #52 for Propane (L.P.), if converted - Propane Rate: 30,000 BTU.

FOR 40 GALLON HEATER:

Orifice size: #38 for Natural / #51 for Propane (L.P.), if converted - Propane Rate: 32,000 BTU.

FOR 50 GALLON HEATER:

Orifice size: #35 for Natural / #51 for Propane (L.P.), if converted - Propane Rate: 38,000 BTU.

- Step 1. Turn gas control knob "A" to "PILOT". Depress and turn "OFF", see Figure 31 page 19.
- Step 2. Remove outer and inner access doors from water heater.
- Step 3. Remove burner assembly from water heater control by first removing 6 screws holding inner door to heater, then loosening 3/4" nut "H" holding burner assembly to control, see figures 32 and 33. Loosen pilot tube nut "J" and thermocouple nut "K" at control. Disconnect wire to Piezo Igniter.
- Step 4. Remove screws "D" disengaging manifold from burner, see Figure 34 page 19.
- Step 5. Remove orifice "E", see Figure 34 page 19 using 3/8" wrench. Install orifice marked "L.P." found in the bag into manifold. Tighten securely. Secure burner to manifold with screws "D".
- Step 6. Loosen pilot tube nut "F", see Figure 35 page 19. Remove orifice "G" and replace with red colored orifice found in bag. Reinstall nut "F" and tighten securely.
- Step 7. Make sure all connections are tightened securely, and reinstall burner assembly into water heater. Position end of manifold inside bracket as shown in Figure 34 page 19. Reinstall manifold into control and tighten 3/4" nut ("H") securely. Recheck to see that end of manifold is still inside bracket as shown in Figure 34 page 19. Reinstall pilot tubing and thermocouple into control, see Figure 32 page 15. Connect wire to Piezo Igniter. Reinstall inner door using the 6 screws removed in Step 3.
- Step 8. Place screwdriver in slot "B", see Figure 31 page 19. Depress and turn counterclockwise (↺) to stop. Control screw must be in "IN" position for propane (L.P.) gas and in "OUT" position for natural gas. STOP! Read label "For Your Safety" located on your water heater.
- Step 9. Set the thermostat to lowest setting by turning the water temperature dial clockwise, (↻) to its lowest temperature setting (with arrow on dial) as shown.

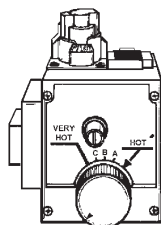

- Step 10. Turn gas control knob clockwise (↻) to "OFF" position. Knob cannot be turned from "PILOT" to "OFF" unless knob is depressed slightly. DO NOT FORCE.
- Step 11. Wait five minutes to clear out any gas. If you then smell gas, STOP! Follow "B" in the safety information on "For Your Safety" label. If you don't smell gas, got to the next step.
- Step 12. The pilot is located in front of the burner, see Figure 33 on page 19.

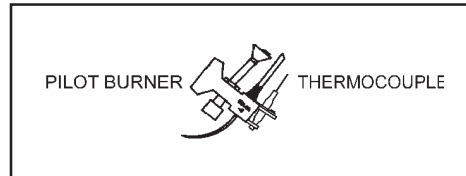

- Step 13. If you don't smell gas, turn knob on gas control counterclockwise (↺) to "PILOT" position.
- Step 14. Push in control knob all the way and hold down. Immediately light the pilot using the Piezo Igniter. Continue to hold control knob in for about one (1) minute after the pilot is lit. Release knob and it will pop back up. Pilot should remain lit. If it goes out, repeat Steps 9 through 12.
 - If knob does not pop up when released, stop and immediately call the local gas supplier.
 - If the pilot will not stay lit after several tries, depress and turn the gas control knob clockwise (↻) to "OFF" and call the gas supplier.
- Step 15. Check for gas leaks with only pilot flame burning using soapy water solution, not a match or open flame. Check for gas leaks at fittings "F" and "G", see Figure 35 page 19 and at fittings "J", see Figure 32 page 19.
- Step 16. Make sure temperature adjustment dial is turned clockwise (↻) in its lowest position, see Figure 31 page 19.
- Step 17. Replace outer door.
- Step 18. At arm's length away turn gas control knob to the full "ON" position. **WARNING: Do not use gas control knob to regulate gas flow.** Turn temperature adjustment dial counterclockwise (↺) until gas flows to main burner and ignites.
- Step 19. With a soapy water solution, not a match or open flame, check for gas leaks at gas connection "H", see Figure 32 page 19. If gas leak occurs, turn off immediately by shutting off gas cock at inlet to control, or by turning gas control knob (↻) to "PILOT" pushing down and turning to "OFF". Repair gas leak as necessary, and repeat Steps 9 through 19.
- Step 20. At arm's length away, set the thermostat to desired setting. The mark (▼) HOT indicative of approx. 120°F (49°C) is preferred starting point. Some local laws may require a lower starting point. If hotter water is desired see the "Temperature Regulation" section in this manual.

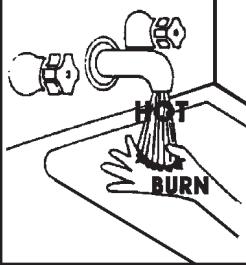
 DANGER	<p>Water temperature over 125°F (52°C) can cause severe burns instantly resulting in severe injury or death.</p> <p>Children, the elderly, and the physically or mentally disabled are at highest risk for scald injury.</p> <p>Feel water before bathing or showering.</p> <p>Temperature limiting valves are available.</p> <p>Read instruction manual for safe temperature setting.</p>
	

Step 21. Replace the outer door if not replaced in Step 17.

Step 22. Remove adhesive label found in conversion kit and place next to rating plate. Mark label indicating for which type gas the water heater is now equipped.

FUEL CONVERSION INSTRUCTIONS FROM PROPANE (L.P.) GAS TO NATURAL GAS

This water heater has been factory equipped to operate with the type gas indicated in the "EQUIPPED FOR" area of the model rating plate located near the gas control valve. The indicated gas may be either Natural or Propane (L.P.). By following the conversion instructions in this manual or the instructions near the gas control valve, the water heater must be converted if it is to be used with the opposite gas. **DO NOT USE THIS WATER HEATER WITH ANY GAS OTHER THAN THE ONE LISTED ON THE MODEL RATING PLATE.** Failure to use the correct gas can cause problems which can result in DEATH, SERIOUS BODILY INJURY, OR PROPERTY DAMAGE. If you have any questions or doubts consult your gas supplier or gas company.

To convert from Propane (L.P.) gas to Natural gas, follow the "Fuel" Conversion Instructions "From Natural Gas to Propane (L.P.) Gas" section except in Step 5, use orifice "E", marked "NAT.". In Step 6 use pilot orifice "G", brass color and in Step 8 turn control screw "B" in Figure 12 clockwise (↻) to stop. Screw must be in "OUT" position for Natural Gas.

See "Instruction Label" for orifice sizes and information below.

FOR 30 GALLON HEATER:

Orifice size: #52 Propane (L.P.) / #40 for Natural, if converted - Natural Rate: 30,000 BTU.

FOR 40 GALLON HEATER:

Orifice size: #51 for Propane (L.P.) / #38 for Natural, if converted - Natural Rate: 32,000 BTU.

FOR 50 GALLON HEATER:

Orifice size: #51 for Propane (L.P.) / #35 for Natural, if converted - Natural Rate: 38,000 BTU.

Maximum Supply Pressure:

10.5" W.C. for Natural Gas.

13" W.C. for Propane (L.P.) Gas.

Minimum Supply Pressure:

5" W.C. for Natural Gas.

11" W.C. for Propane (L.P.) Gas.

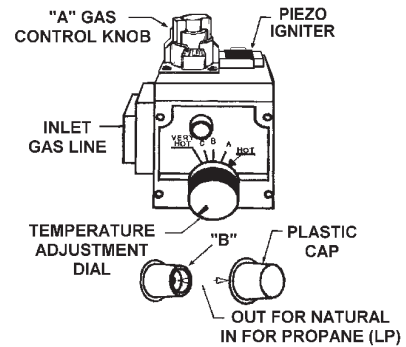

FIGURE 31.

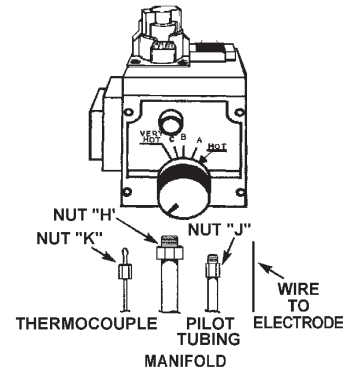

FIGURE 32.

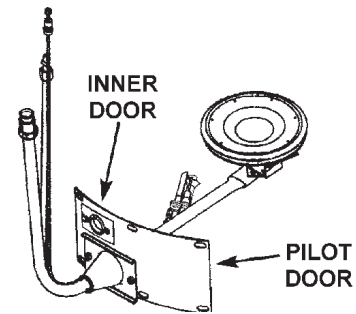

FIGURE 33.

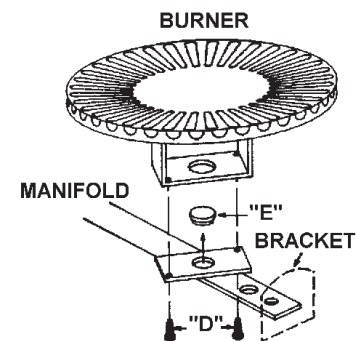

FIGURE 34.

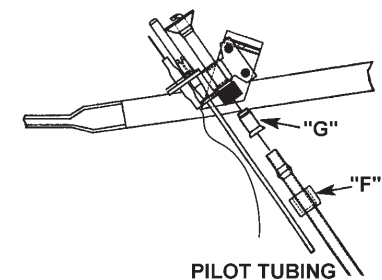

FIGURE 35.

FOR YOUR SAFETY READ BEFORE LIGHTING



WARNING: If you do not follow these instructions exactly, a fire or explosion may result causing property damage, personal injury or loss of life.



BEFORE LIGHTING: ENTIRE SYSTEM MUST BE FILLED WITH WATER AND AIR PURGED FROM ALL LINES

- A. This appliance has a pilot which is lit by a piezo-electric spark gas ignition system. Do not open the inner door of the appliance and try to light the pilot by hand.
- B. BEFORE LIGHTING smell all around the appliance area for gas. Be sure to smell next to the floor because some gas is heavier than air and will settle on the floor.

WHAT TO DO IF YOU SMELL GAS

- Do not try to light any appliance.
- Do not touch any electric switch; do not use any phone in your building.
- Immediately call your gas supplier from a neighbor's phone. Follow the gas supplier's instructions.

- If you cannot reach your gas supplier, call the fire department.

C. Use only your hand to push in or turn the gas control knob. Never use tools. If the knob will not push in or turn by hand, don't try to repair it, call a qualified service technician. Force or attempted repair may result in a fire or explosion.

D. Do not use this appliance if any part has been under water. Immediately contact a qualified installer or service agency to replace a flooded water heater. Do not attempt to repair the unit! It must be replaced!

LIGHTING INSTRUCTIONS

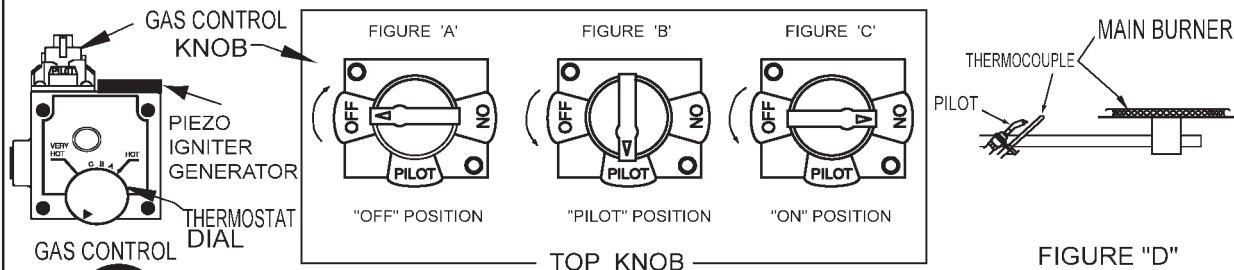

1. **STOP!** Read the safety information above on this label.
2. Set the thermostat to lowest setting. Turn thermostat dial fully clockwise until it stops.
3. Push the gas control knob down slightly and turn clockwise to "OFF". SEE FIGURE 'A'. NOTE: Knob cannot be turned from "PILOT" to "OFF" unless knob is pushed down slightly. Do not force.
4. Remove the outer burner door located below the gas control.
5. Wait five (5) minutes to clear out any gas. If you then smell gas, **STOP!** Follow "B" in the safety information above on this label. If you don't smell gas, go to next step.
6. This unit is equipped with a push button pilot igniter, which is used to light the pilot. Locate the igniter on the gas control.
7. Turn gas control knob counterclockwise to "PILOT". SEE FIGURE 'B'.
8. The pilot is located in front of the burner. It can be located by looking through the glass view port while pressing the piezo igniter button several times. Look for a spark at the pilot location, Figure "D".

9. Once the pilot has been found, push the gas knob all the way down. Immediately press the pilot igniter button rapidly (4) to (5) times. If the pilot will not light, repeat step (3) through (9).
10. Continue to hold the gas control knob down for about one (1) minute after the pilot is lit. Release the gas control knob and it will pop back up. Pilot should remain lit. If it goes out, repeat step (3) through (9). It may take several minutes for air to clear the lines before the pilot will light.
 - If knob does not pop up when released, stop and immediately call your service technician or gas supplier.
 - If the pilot will not stay lit after several tries, turn the gas control knob clockwise to 'OFF' and call your service technician or gas supplier. SEE FIGURE 'A'
11. Once the pilot flame is established replace the outer burner door.
12. Turn gas control knob counterclockwise to 'ON'. SEE FIGURE 'C'
13. Set thermostat to desired setting.



DANGER: Hotter water increases the risk of scald injury. Consult the instruction manual before changing temperature.

TO TURN OFF GAS TO APPLIANCE

1. Set the thermostat to lowest setting.
2. Push gas control knob down slightly and turn clockwise to 'OFF'. Do not force. SEE FIGURE 'A'.

TEMPERATURE REGULATION

Short repeated heating cycles caused by small hot water uses can cause temperatures at the point of use to exceed the thermostat setting by up to 30°F (16.7°C). If you experience this type of use you should consider using lower temperature settings to reduce scald hazards.

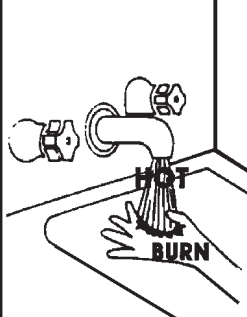

▲ DANGER Water temperature over 125°F (52°C) can cause severe burns instantly resulting in severe injury or death.

Children, the elderly, and the physically or mentally disabled are at highest risk for scald injury.

Feel water before bathing or showering.

Temperature limiting valves are available.

Read instruction manual for safe temperature setting.

HOTTER WATER CAN SCALD: Water heaters are intended to produce hot water. Water heated to a temperature which will satisfy space heating, clothes washing, dish washing, and other sanitizing needs can scald and permanently injure you upon contact. Some people are more likely to be permanently injured by hot water than others. These include the elderly, children, the infirm, or physically/mentally handicapped. If anyone using hot water in your home fits into one of these groups or if there is a local code or state law requiring a certain temperature water at the hot water tap, then you must take special precautions. In addition to using the lowest possible temperature setting that satisfies your hot water needs, a means such as a mixing valve, shall be used at the hot water taps used by these people or at the water heater. Mixing valves are available at plumbing supply or hardware stores, see Figure 2. Follow manufacturer's instructions for installation of the valves. Before changing the factory setting on the thermostat, read the "Temperature Regulation" section in this manual, see Figures 36 and 37.

Never allow small children to use a hot water tap, or to draw their own bath water. Never leave a child or handicapped person unattended in a bathtub or shower.

NOTE: A water temperature range of 120°F-140°F (49°C-60°C) is recommended by most dishwasher manufacturers.

The thermostat of this water heater has been factory set at its lowest position. It is adjustable and must be reset to the desired temperature setting to reduce the risk of scald injury. The mark (▼) indicative of approximately 120°F (49°C) is preferred starting point. Some States have a requirement for a lower setting.

Turn the water temperature dial clockwise (↻) to decrease the temperature, or counterclockwise (↻) to increase the temperature.

Should overheating occur or the gas supply fail to shut off, turn off the manual gas control valve to the appliance.

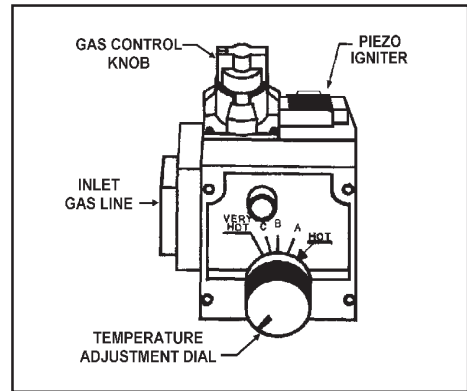

FIGURE 36.

Temperature Settings	Time to Produce 2nd & 3rd Degree Burns on Adult Skin
VERY HOT= approx. 160°F (71°C)	About 1/2 second
C = approx. 150°F (66°C)	About 1-1/2 seconds
B = approx. 140°F (60°C)	Less than 5 seconds
A = approx. 130°F (54°C)	About 30 seconds
▲ = approx. 120°F (49°C)	More than 5 minutes
Lowest Setting = approx. 80°F (27°C)	-----

FIGURE 37.

FOR YOUR INFORMATION

START UP CONDITIONS

CONDENSATE

Whenever the water heater is filled with cold water, some condensate will form while the burner is on. A water heater may appear to be leaking when in fact the water is condensation. This usually happens when:

- A new water heater is filled with cold water for the first time.
- Burning gas produces water vapor in water heaters, particularly high efficiency models where flue temperatures are lower.
- Large amounts of hot water are used in a short time and the refill water in the tank is very cold.

Moisture from the products of combustion condense on the cooler tank surfaces and form drops of water which may fall onto the burner or other hot surfaces to produce a "sizzling" or "frying" noise.

Excessive condensation can cause pilot outage due to water running down the flue tube onto the main burner and putting out the pilot.

Because of the suddenness and amount of water, condensation water may be diagnosed as a "tank leak". After the water in the tank warms up (about 1-2 hours), the condition should disappear.

Do not assume the water heater is leaking until there has been enough time for the water in the tank to warm up.

An undersized water heater will cause more condensation. The water heater must be sized properly to meet the family's demands for hot water including dishwashers, washing machines and shower heads.

Excessive condensation may be noticed during the winter and early spring months when incoming water temperatures are at their lowest.

Good venting is essential for a gas fired water heater to operate properly as well as to carry away products of combustion and water vapor.

SMOKE/ODOR

It is not uncommon to experience a small amount of smoke and odor during the initial start-up. This is due to burning off of oil from metal parts, and will disappear in a short while.

THERMAL EXPANSION

CAUTION
Property Damage Hazard
<ul style="list-style-type: none">• Avoid water heater damage.• Install thermal expansion tank or device if necessary.• Contact qualified installer or service agency.

Water supply systems may, because of such events as high line pressure, frequent cut-offs, the effects of water hammer among others, have installed devices such as pressure reducing valves, check valves, back flow preventers, etc. to control these types of problems. When these devices are not equipped with an internal by-pass, and no other measures are taken, the devices cause the water system to be closed. As water is heated, it expands (thermal expansion) and closed systems do not allow for the expansion of heated water.

The water within the water heater tank expands as it is heated and increases the pressure of the water system. If the relieving point of the water heater's temperature-pressure relief valve is reached, the valve will relieve the excess pressure. **The temperature-pressure relief valve is not intended for the constant relief of thermal expansion.** This is an unacceptable condition and must be corrected. It is recommended that any devices installed which could create a closed system have a by-pass and/or the system have an expansion tank or device to relieve the pressure built by thermal expansion in the water system. Expansion tanks are available for ordering through a local plumbing contractor. Contact the local water heater supplier or service agency for assistance in controlling these situations.

STRANGE SOUNDS

Possible noises due to expansion and contraction of some metal parts during periods of heat-up and cool-down do not necessarily represent harmful or dangerous conditions.

Condensation causes sizzling and popping within the burner area during heating and cooling periods and should be considered normal. See "Condensation" in this section.

OPERATIONAL CONDITIONS

SMELLY WATER

In each water heater there is installed at least one anode rod (see parts sections) for corrosion protection of the tank. Certain water conditions will cause a reaction between this rod and the water. The

most common complaint associated with the anode rod is one of a "rotten egg smell" in the hot water. This odor is derived from hydrogen sulfide gas dissolved in the water. The smell is the result of four factors which must all be present for the odor to develop:

- a. A concentration of sulfate in the supply water.
- b. Little or no dissolved oxygen in the water.
- c. A sulfate reducing bacteria which has accumulated within the water heater (this harmless bacteria is nontoxic to humans).
- d. An excess of active hydrogen in the tank. This is caused by the corrosion protective action of the anode.

Smelly water may be eliminated or reduced in some water heater models by replacing the anode(s) with one of less active material, and then chlorinating the water heater tank and all hot water lines. Contact the local water heater supplier or service agency for further information concerning an Anode Replacement Kit and this chlorination treatment.

If the smelly water persists after the anode replacement and chlorination treatment, we can only suggest that chlorination or aeration of the water supply be considered to eliminate the water problem.

Do not remove the anode leaving the tank unprotected. By doing so, all warranty on the water heater tank is voided.

"AIR" IN HOT WATER FAUCETS

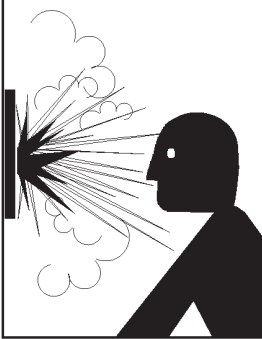
	WARNING
	Explosion Hazard
	<ul style="list-style-type: none">• Flammable hydrogen gases may be present.• Keep all ignition sources away from faucet when turning on hot water.

HYDROGEN GAS: Hydrogen gas can be produced in a hot water system that has not been used for a long period of time (generally two weeks or more). Hydrogen gas is extremely flammable and explosive. To prevent the possibility of injury under these conditions, we recommend the hot water faucet, located farthest away, be opened for several minutes before any electrical appliances which are connected to the hot water system are used (such as a dishwasher or washing machine). If hydrogen gas is present, there will probably be an unusual sound similar to air escaping through the pipe as the hot water faucet is opened. There must be no smoking or open flame near the faucet at the time it is open.

HIGH WATER TEMPERATURE SHUT OFF SYSTEM

This water heater is equipped with an automatic gas Shut-off system. This system works when high water temperatures are present. Turn "OFF" the entire gas supply to the water heater. The high temperature Shut-off is built into the gas control valve. It is non-resettable. If the high temperature Shut-off activates, the gas control valve must be replaced. Contact your gas supplier or service agency.

PERIODIC MAINTENANCE

VENTING SYSTEM INSPECTION

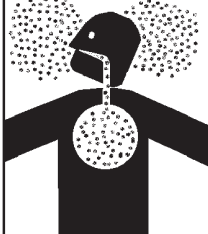
⚠ WARNING	
Breathing Hazard - Carbon Monoxide Gas	
	<ul style="list-style-type: none">• Flue gases may escape if vent pipe is not connected.• Be alert for obstructed, sooted or deteriorated vent system to avoid serious injury or death.• Do not store corrosive chemicals in vicinity of water heater.• Chemical corrosion of flue and vent system can cause serious injury or death.
Breathing carbon monoxide can cause brain damage or death. Always read and understand instruction manual.	

At least once a year a visual inspection should be made of the venting system. You should look for:

1. Obstructions which could cause improper venting. The combustion and ventilation air flow must not be obstructed.
2. Damage or deterioration which could cause improper venting or leakage of combustion products.
3. Rusted flakes around top of water heater.

Be sure the vent piping is properly connected to prevent escape of dangerous flue gasses which could cause deadly asphyxiation.

Obstructions and deteriorated vent systems may present serious health risk or asphyxiation.

Chemical vapor corrosion of the flue and vent system may occur if air for combustion contains certain chemical vapors. Spray can propellants, cleaning solvents, refrigerator and air conditioner refrigerants, swimming pool chemicals, calcium and sodium chloride, waxes, bleach and process chemicals are typical compounds which are potentially corrosive.

If after inspection of the vent system you found sooting or deterioration, something is wrong. Call the local gas utility to correct the problem and clean or replace the flue and venting before resuming operation of the water heater.

BURNER INSPECTION

Flood damage to a water heater may not be readily visible or immediately detectable. However, over a period of time a flooded water heater will create dangerous conditions which can cause **DEATH, SERIOUS BODILY INJURY, OR PROPERTY DAMAGE**. Contact a qualified installer or service agency to replace a flooded water heater. Do not attempt to repair the unit! It must be replaced!

At least once a year a visual inspection should be made of the main burner and pilot burner, see Figure 38.

You should check for sooting. Soot is not normal and will impair proper combustion.

Soot build-up indicates a problem that requires correction before further use. Turn "OFF" gas to water heater and leave off until repairs are made, because failure to correct the cause of the sooting can result in a fire causing death, serious injury, or property damage.

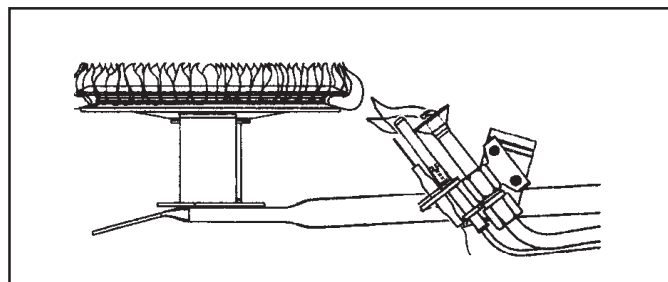

FIGURE 38.

BURNER CLEANING

In the event your burner needs cleaning, follow these instructions:

If inspection of the burner shows that cleaning is required, turn the gas control knob clockwise (↻) to the "OFF" position, depressing slightly.

NOTE: The knob cannot be turned from "PILOT" to "OFF" unless knob is depressed slightly. DO NOT FORCE.

The burner needs to be removed for cleaning. Call a service agency to remove and clean the burner and correct the problem that required the burner to be cleaned.

HOUSEKEEPING

Vacuum around base of water heater for dust, dirt, and lint on a regular basis.

⚠ DANGER	
Fire and Explosion Hazard	
	<ul style="list-style-type: none">• Do not obstruct combustion air openings at the bottom of the water heater.• Do not use or store flammable vapor products such as gasoline, solvents or adhesives in the same room or area near water heater or other appliance.• Can cause serious injury or death.

INSTALLED IN SUITABLE AREA: To insure sufficient ventilation and combustion air supply, proper clearances from the water heater must be maintained. See "Locating the New Water Heater" section. Combustible materials such as clothing, cleaning materials, or flammable liquids, etc. must not be placed against or adjacent to the water heater which can cause a fire.

ANODE ROD INSPECTION

CAUTION

Property Damage Hazard

- Avoid water heater damage.
- Inspection and replacement of anode rod as needed.

The anode rod is used to protect the tank from corrosion. Most hot water tanks are equipped with an anode rod. The submerged rod sacrifices itself to protect the tank. Instead of corroding the tank, water ions attack and eat away the anode rod. This does not affect the water's taste or color. The rod must be maintained to keep the tank in operating condition.

Anode deterioration depends on water conductivity, not necessarily water condition. A corroded or pitted anode rod indicates high water conductivity and should be checked and/or replaced more often than an anode rod that appears to be intact. Replacement of a depleted anode rod can extend the life of your water heater. Inspection should be conducted by a qualified technician, and at a minimum should be checked annually after the warranty period.

TEMPERATURE-PRESSURE RELIEF VALVE OPERATION

⚠ DANGER

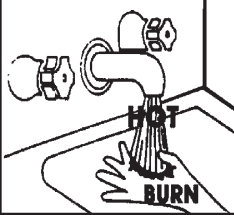

- Burn hazard
- Hot water discharge.
- Keep clear of relief valve discharge outlet.

The temperature-pressure relief valve must be manually operated at least once a year.

When checking the temperature-pressure relief valve operation, make sure that (1) no one is in front of or around the outlet of the temperature-pressure relief valve discharge line, and (2) that the water discharge will not cause any property damage, as the water may be extremely hot, see Figure 39.

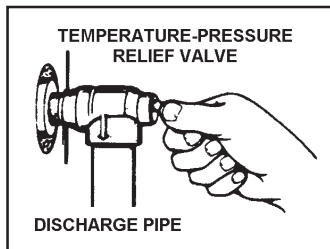

FIGURE 39.

If after manually operating the valve, it fails to completely reset and continues to release water, immediately close the cold water inlet to the water heater, follow the draining instructions, and replace the temperature-pressure relief valve with a new one.

If the temperature-pressure relief valve on the appliance weeps or discharges periodically, this may be due to thermal expansion. You

may have a check valve installed in the water line or a water meter with a check valve. Consult your local water supplier or service agency for further information. Do not plug the temperature-pressure relief valve.

DRAINING

⚠ DANGER

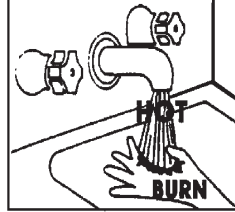

- Burn hazard
- Hot water discharge.
- Keep hands clear of drain valve discharge.

The water heater should be drained if being shut down during freezing temperatures. Also periodic draining and cleaning of sediment from the tank may be necessary.

1. Turn the gas control knob to the "OFF" position.
 2. CLOSE the cold water inlet valve to the water heater.
 3. OPEN a nearby hot water faucet and leave open to allow for draining.
 4. Connect a hose to the drain valve and terminate to an adequate drain.
 5. OPEN the water heater drain valve to allow for tank draining.
- NOTE:** If the water heater is going to be shut down and drained for an extended period, the drain valve should be left open with hose connected allowing water to terminate to an adequate drain.
6. CLOSE the drain valve.
 7. Follow instructions in the "Filling The Water Heater" section.
 8. Follow the lighting instructions on the label or see page 20 under "Lighting Instructions" to restart the water heater.

DRAIN VALVE WASHER REPLACEMENT

(See Figure 40)

1. Turn "OFF" gas supply to water heater.
2. Follow "Draining" instructions.
3. Turning counterclockwise (↺), remove the hex cap below the screw handle.
4. Remove the washer and put the new one in place.
5. Screw the handle and cap assembly back into the drain valve and retighten using a wrench. DO NOT OVER TIGHTEN.
6. Follow instructions in the "Filling The Water Heater" section.
7. Check for leaks.
8. Follow the lighting instructions on the "Lighting & Operating Label" section to restart the water heater.

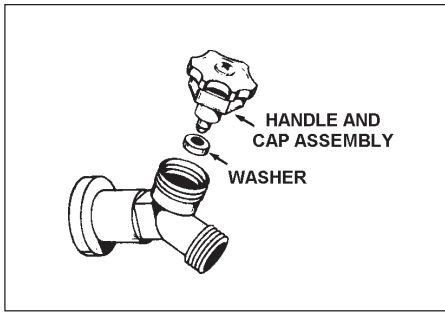

FIGURE 40.

SERVICE

If a condition persists or you are uncertain about the operation of the water heater contact a service agency.

Use this guide to check a "Leaking" water heater. Many suspected "Leakers" are not leaking tanks. Often the source of the water can be found and corrected.

If you are not thoroughly familiar with gas codes, your water heater, and safety practices, contact your gas supplier or qualified installer to check the water heater.

LEAKAGE CHECKPOINTS

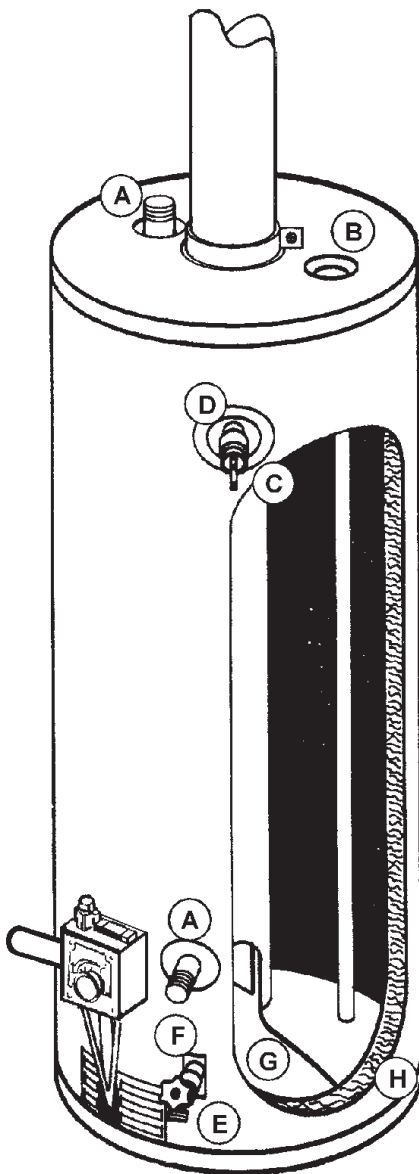

FIGURE 41.

Read this manual first. Then before checking the water heater make sure the gas supply has been turned "OFF", and never turn the gas "ON" before the tank is completely full of water.

- A. *Condensation may be seen on pipes in humid weather or pipe connections may be leaking.
- B. *The anode rod fitting may be leaking.
- C. Small amounts of water from temperature-pressure relief valve may be due to thermal expansion or high water pressure in your area.
- D. *The temperature-pressure relief valve may be leaking at the tank fitting.
- E. Water from a drain valve may be due to the valve being slightly opened.
- F. *The drain valve may be leaking at the tank fitting.
- G. Combustion products contain water vapor which can condense on the cooler surfaces of the tank. Droplets form and drip onto the burner or run on the floor. This is common at the time of start-up after installation and when incoming water is cold.
- H. Water in the water heater bottom or on the floor may be from condensation, loose connections, or the relief valve. DO NOT replace the water heater until a full inspection of all possible water sources is made and necessary corrective steps taken.

Leakage from other appliances, water lines, or ground seepage should also be checked.

- * To check where threaded portion enters tank, insert cotton swab between jacket opening and fitting. If cotton is wet, follow "Draining" instructions in the "Periodic Maintenance" section and then remove fitting. Put pipe dope or teflon tape on the threads and replace. Then follow "Filling the Water Heater" instructions in the "Installing the New Water Heater" section.

	! WARNING
	<p>Read and understand instruction manual and safety messages before installing, operating or servicing this water heater.</p>
	<p>Failure to follow instructions and safety messages could result in death or serious injury.</p> <p>Instruction Manual must remain with water heater.</p>

TROUBLESHOOTING GUIDELINES

These guidelines should be utilized by a qualified service agent.

Problem	Cause	Solution
WATER LEAKS	Improperly sealed, hot or cold supply connection, relief valve, drain valve, or thermostat threads.	Tighten threaded connections.
	Leakage from other appliances or water lines.	Inspect other appliances near water heater.
	Condensation of flue products.	Refer to CONDENSATION.
LEAKING T&P VALVE	Thermal expansion in closed water system.	Install thermal expansion tank (DO NOT plug T&P valve).
	Improperly seated valve.	Check relief valve for proper operation (DO NOT plug T&P valve).
HOT WATER ODORS	High sulfate or mineral content in water supply.	Drain and flush heater thoroughly, then refill.
	Bacteria in water supply.	Chlorinate or aerate water supply.
PILOT OUTAGE	Dirty pilot burner.	Clean pilot assembly.
	Thermocouple tip is not in contact with pilot flame.	Insert thermocouple correctly.
	Thermocouple malfunction.	Replace thermocouple.
	Thermocouple malfunction.	Check thermostat.
PILOT WILL NOT LIGHT	Gas knob dial not positioned correctly.	Refer to LIGHTING INSTRUCTIONS.
	Pilot orifice clogged.	Clean or replace pilot orifice.
	Pinched or clogged pilot tube.	Replace pilot tube.
	Main gas supply off.	Turn on main gas shut-off valve.
NOT ENOUGH OR NO HOT WATER	Heater not lit or thermostat not on.	Refer to LIGHTING INSTRUCTIONS.
	Thermostat set too low.	Refer to TEMPERATURE REGULATION.
	Heater undersized.	Reduce the hot water use.
	Low gas pressure.	Contact dealer.
	Incoming water is unusually cold.	Allow more time for heater to re-heat.
	Leaking hot water pipes or fixtures.	Have a plumber check and repair leaks.
WATER TOO HOT	High temperature limit switch activated.	Contact a Service Agency to determine cause.
	Thermostat set too high.	Refer to HIGH TEMPERATURE REGULATION.
WATER HEATER SOUNDS: SIZZLING - RUMBLING	Condensate dripping on burner.	Refer to CONDENSATE.
	Sediment at bottom of heater tank.	Clean sediment from tank. Refer to DRAINING instructions in Maintenance section of manual.
SOOTING	Improper combustion.	Refer to FACTS TO CONSIDER ABOUT THE LOCATION, see Figure 2 on page 6.

REPAIR PARTS LIST

Key No.	Part Description
1	Air Duct Assembly (12" to 24" Long)
2	Angle Bracket (2 Required)
3	Angle Bracket
4	Anode Rod
5	Sight Glass Assembly
6	Burner
7	Burner Manifold
8	Burner Orifice (Natural Gas)
8	Burner Orifice (Propane [L.P.] Gas)
9	Burner Access Door Assembly
10	Drain Pan
11	Drain Valve
#12	Drain Valve Washer (17/32"x13/64"x1/8" thick)*
13	10" Extension Pipe (Optional)
14	Flue Baffle
15	Gas Control Valve
16	Gasket - Air Intake
17	Piezo Igniter Assembly
18	Nipple w/Heat Traps
19	Outer Door
#20	Optional 3" Outside Wall Intake Air Vent Kit 9002986
#20	Optional 4" Outside Wall Intake Air Vent Kit 9002987
21	Pilot Burner (Natural) Gas
21	Pilot Burner (Propane [L.P.] Gas)
22	Pilot Tubing w/Fittings
23	Pipe Insulation
24	Roof Jack 12" (9002964)
24	Roof Jack 32" (9002965)
24	Roof Jack 60" (9002966)
24	Roof Jack 95" (9002967)
25	Securing Clamp Assembly
26	T & P Insulation
27	Temperature-Pressure Relief Valve
28	Thermocouple
29	Thermostat Shield
30	Vent Cap

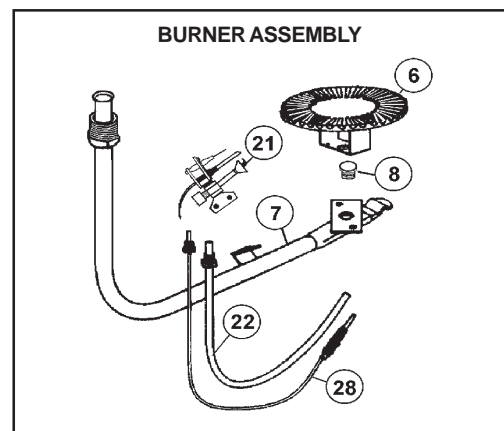
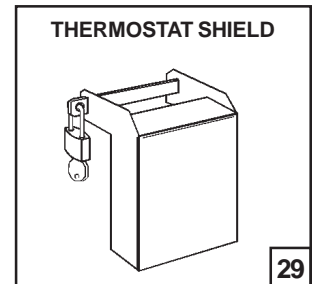
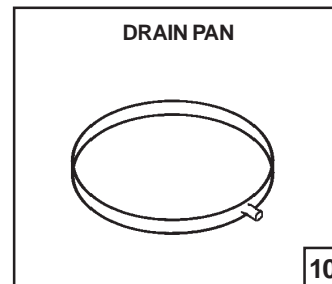
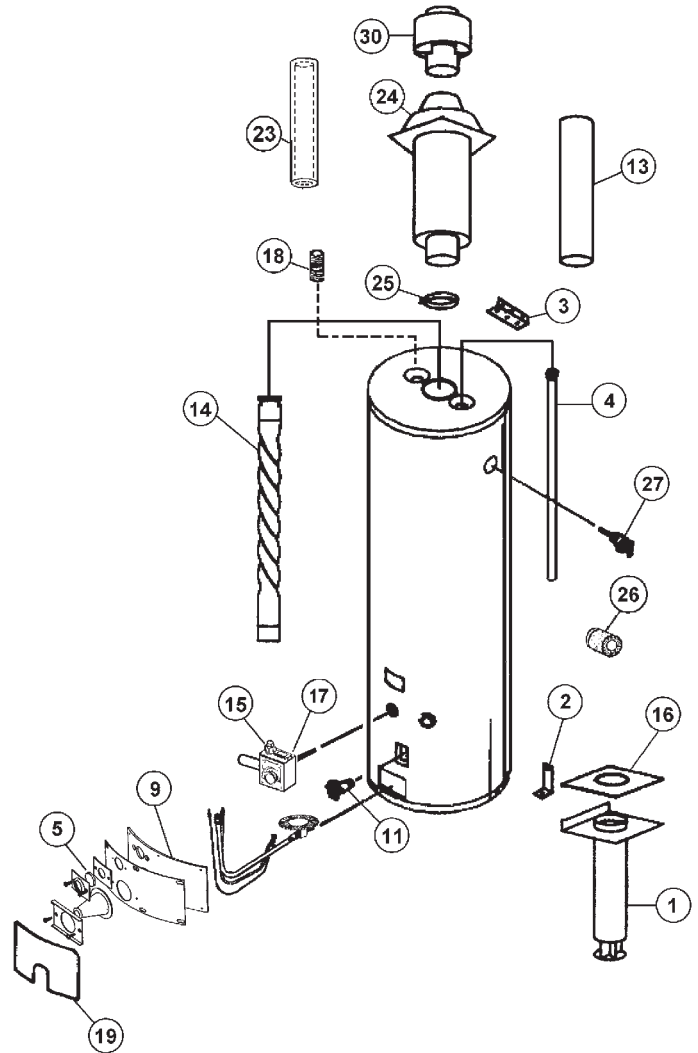

* These parts available at most hardware stores.
Not Shown.

Now that you have purchased this water heater, should a need ever exist for repair parts or service, simply contact the company it was purchased from or direct from the manufacturer listed on the rating plate on the water heater.

Be sure to provide all pertinent facts when you call or visit.

Selling prices will be furnished on request or parts will be shipped at prevailing prices and you will be billed accordingly.

The model number of your Gas Water Heater will be found on the rating plate located above the gas control valve.

WHEN ORDERING REPAIR PARTS, ALWAYS GIVE THE FOLLOWING INFORMATION:

- MODEL NUMBER
- TYPE GAS (NATURAL OR PROPANE (L.P.))
- SERIAL NUMBER
- PART DESCRIPTION

THIS IS A REPAIR PARTS LIST, NOT A PACKING LIST.

